

ALL NUMBERING BEGINS FROM THE NORTHWEST CORNER AND GOES CLOCKWISE. EACH CORNER HAS ITS SPECIFIC NUMBER THAT SHALL BE USED IF CURB RAMPS ARE IN THESE LOCATIONS.

* MEDIAN RAMPS ON THE WEST AND/OR EAST LEGS WOULD BE M1, M8, AND M4, M5 RESPECTIVELY.

INTERSECTION CURB RAMP NUMBERING SYSTEM

CITY OF COLUMBUS, OHIO
DEPARTMENT OF PUBLIC SERVICE
DIVISION OF DESIGN AND CONSTRUCTION

STD DWG
2319

07/01/2024

CITY ENGINEER

SHT 1 OF 23

GENERAL NOTES, CURB RAMPS

1. CURB RAMPS SHALL BE INSTALLED PER STD DWGS 2300, 2303, 2319, CMSC 608, AND CITY OF COLUMBUS ADA RULES AND REGULATIONS.
2. MATERIAL: THE RAMP PANEL AND FLARED SIDES SHALL BE CONCRETE.
3. RAMP TYPES ARE CATEGORIZED BELOW IN TIERS BY REQUIRED ORDER OF USE. LOCATING THE RAMP AS CLOSE AS POSSIBLE TO THE INTERSECTION FOLLOWING THE CURB RAMP DESIGN BOUNDARY CONTAINED IN THE ADA RULES AND REGULATIONS IS THE FIRST PRIORITY. THE DESIGNER SHALL NOT USE A LOWER TIERED RAMP WITHOUT FIRST DETERMINING AND HAVING JUSTIFICATION THAT THE UPPER TIER RAMPS ARE NOT CONSTRUCTIBLE.

CITY OF COLUMBUS RAMP TYPE HIERARCHY

TIER 1 (THESE PERPENDICULAR RAMPS SHOULD BE USED WHENEVER POSSIBLE.)

- TYPE A
- TYPE C
- TYPE D

TIER 2 (PARALLEL RAMPS SHOULD ONLY BE USED DUE TO RIGHT OF WAY (ROW) OR OTHER SPACE CONSTRAINTS WHERE A TIER 1 RAMP CANNOT BE USED).

- TYPE P-6
- TYPE P-7
- TYPE P-5
- TYPE P-4

TIER 3 (TIER 3 RAMPS CAN ONLY BE USED WITH WRITTEN APPROVAL BY THE CITY ENGINEER OR DESIGNEE. TIER 3 RAMPS SHALL BE IDENTIFIED IN THE DESIGN SCOPE OR APPROVAL REQUESTED BY THE DESIGNER JUSTIFYING THAT THIS RAMP TYPE IS NECESSARY.)

- TYPE J (MODIFIED ALLEY RAMP), USE SHOULD BE LIMITED DUE TO DRAINAGE CONCERNS
- RADIAL RAMPS
- SINGLE SHARED RAMPS

SPECIALTY RAMPS (SHALL ONLY BE USED FOR THE LISTED SITUATION, OR WRITTEN APPROVAL BY THE CITY ENGINEER OR DESIGNEE.)

- TYPE G - ONLY TO BE USED ON ALLEY CROSSINGS
 - TYPE H - ONLY TO BE USED ON ALLEY CROSSINGS
 - TYPE L-1 - ONLY FOR MEDIAN CROSSINGS
 - TYPE L-2 - ONLY FOR MEDIAN CROSSINGS
 - PEDESTRIAN PADS - USED FOR ACCESS TO PUSHBUTTONS WHERE THERE IS NO EXISTING SIDEWALK. THE INTENT IS TO PROVIDE ACCESS TO CROSS THE INTERSECTION IN BOTH DIRECTIONS WITHOUT ENTERING THE STREET TO ACCESS TO OTHER CROSSING. THE FOLLOWING IS THE ORDER OF PREFERENCE ON PEDESTRIAN PADS:
 1. PP-1 TWO CONNECTED RAMPS WITH UTILITY STRIP
 2. PP-2 TWO CONNECTED RAMPS WITH SIDEWALK AGAINST CURB
 3. PP-3 USED AS SINGLE SHARED RAMP THAT CAN ACCESS BOTH CROSSWALK LEGS AND THE PUSHBUTTON
 4. PP-3 USED TO ONLY ACCESS THE LEG OF THE INTERSECTION CONTROLLED BY THE PUSHBUTTON
4. RAMP RUNNING SLOPE: THE RUNNING SLOPE SHALL BE NO GREATER THAN 7.7%. THE MINIMUM SLOPE FOR ANY RAMP SHALL BE 5.0% AND SHOULD BE MAXIMIZED UP TO 7.7% WHENEVER POSSIBLE FOR DRAINAGE.
 5. ALL JOINTS BETWEEN NEW AND EXISTING MATERIALS SHALL BE FLUSH.
 6. LANDING SLOPES SHALL BE 1.6% MAXIMUM PARALLEL AND PERPENDICULAR TO THE RAMP RUNNING SLOPE.

**CURB RAMP
GENERAL NOTES**

CITY OF COLUMBUS, OHIO
DEPARTMENT OF PUBLIC SERVICE
DIVISION OF DESIGN AND CONSTRUCTION

STD DWG
2319

07/01/2024

SHT 2 OF 23

- ALL PERPENDICULAR RAMPS SHALL HAVE A LANDING NO LESS THAN 4-FT MINIMUM BY 4-FT.
 - LANDING AT INTERSECTING SIDEWALKS - WHEREVER SIDEWALKS INTERSECT, THERE SHALL BE A LANDING.
7. AT GUTTERS AND STREETS WHERE A CHANGE OF GRADE OCCURS ADJACENT TO CURB RAMPS AND BLENDED TRANSITIONS, THE CHANGE OF GRADE SHALL NOT EXCEED 13.3%.
 8. CLEAR SPACE: AT MARKED CROSSINGS THE RAMP AND STREET CLEAR SPACE MUST BE FULLY CONTAINED WITHIN THE MARKED CROSSWALK. AT UNMARKED CROSSINGS THE RAMP AND CLEAR SPACE MUST BE WITHIN THE CURB RAMP DESIGN BOUNDARY.
 9. SURFACES: RAMP, FLARE, AND LANDING SURFACES MUST BE STABLE AND SLIP RESISTANT. RAMPS SHALL BE BROOM FINISHED, TRANSVERSE TO THE DIRECTION OF TRAVEL. GRATINGS, VALVE BOXES, AND UTILITY BOXES SHALL NOT BE LOCATED IN THE RAMP OR LANDING.
 10. DETECTABLE WARNINGS: DETECTABLE WARNINGS SHALL BE INSTALLED ACCORDING TO THESE STANDARD DRAWINGS, CMSC 608, AND CITY OF COLUMBUS ADA RULES AND REGULATIONS.
 11. CURB, BACK OF WALK, MAY BE REQUIRED FOR CURB RAMP CONSTRUCTION WHERE SPACE RESTRICTION DOES NOT ALLOW FOR GRADING WITHIN ROW AT A 3:1 SLOPE OR FLATTER. THE CURB SHALL BE NON-REINFORCED 6" THICK CONCRETE AND 6" TO 12" IN HEIGHT. THE BURIED PORTION OF THE CURB SHALL BE 12". RETAINING EMBANKMENT TO A HEIGHT OF MORE THAN 12" ABOVE THE SIDEWALK SURFACE WILL REQUIRE A DESIGNED RETAINING WALL OR CELLULAR WALL. SEE STD. DWG. 2001
 12. RAMPS MUST BE CONSTRUCTED TO ALLOW FOR POSITIVE DRAINAGE. THE RAMP ITSELF SHALL NOT HOLD EXCESS WATER AND THE ADJACENT PAVEMENT SHALL NOT BE ALTERED TO INHIBIT FLOW OF WATER. IF AN EXISTING CONSTRAINT PREVENTS BUILDING THE RAMP AND ADJACENT AREA WITH POSITIVE DRAINAGE IT MUST BE BROUGHT TO THE CITY'S ATTENTION PRIOR TO CONSTRUCTION AND FINAL DESIGN APPROVED BY THE CITY.
 13. DETECTABLE WARNINGS SHALL BE PROVIDED WHEREVER A CURB RAMP CROSSES A VEHICULAR WAY. EXCLUDING MOST UNSIGNALIZED DRIVEWAY CROSSINGS. SEE CITY OF COLUMBUS ADA RULES AND REGULATIONS FOR MORE INFORMATION.
 14. DETECTABLE WARNINGS SHALL BE PROVIDED 24" IN THE DIRECTION OF TRAVEL AND EXTEND THE FULL WIDTH OF THE CURB RAMP OR FLUSH SURFACE. THE DETECTABLE WARNING SHALL BE LOCATED ADJACENT TO THE CURB LINE.
 15. MATERIALS SHALL COMPLY WITH CMSC 608 AND CITY OF COLUMBUS ADA RULES AND REGULATIONS.
 16. DETECTABLE WARNINGS SHALL BE PLACED 6" TO 8" BEHIND THE FACE OF CURB AND BEHIND THE CURB JOINT.
 17. CAST IN PLACE OR ANY NON-SURFACE APPLIED DETECTABLE WARNING SHALL HAVE A MINIMUM OF 2" OF CONCRETE ON EACH SIDE OF THE WARNING.

CURB RAMP GENERAL NOTES

CITY OF COLUMBUS, OHIO
DEPARTMENT OF PUBLIC SERVICE
DIVISION OF DESIGN AND CONSTRUCTION

STD DWG

2319

07/01/2024

SHT 3 OF 23

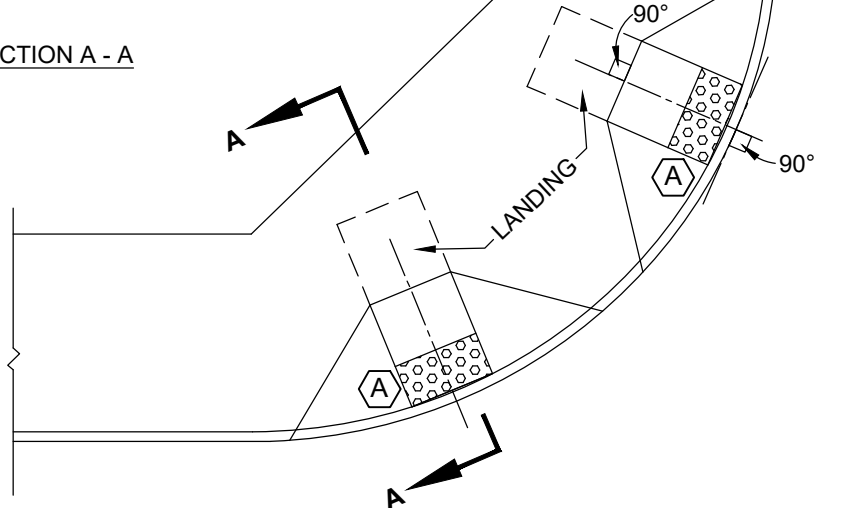
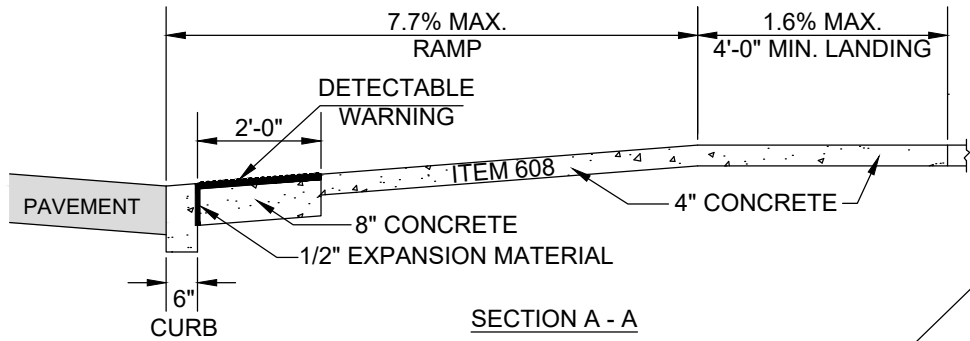
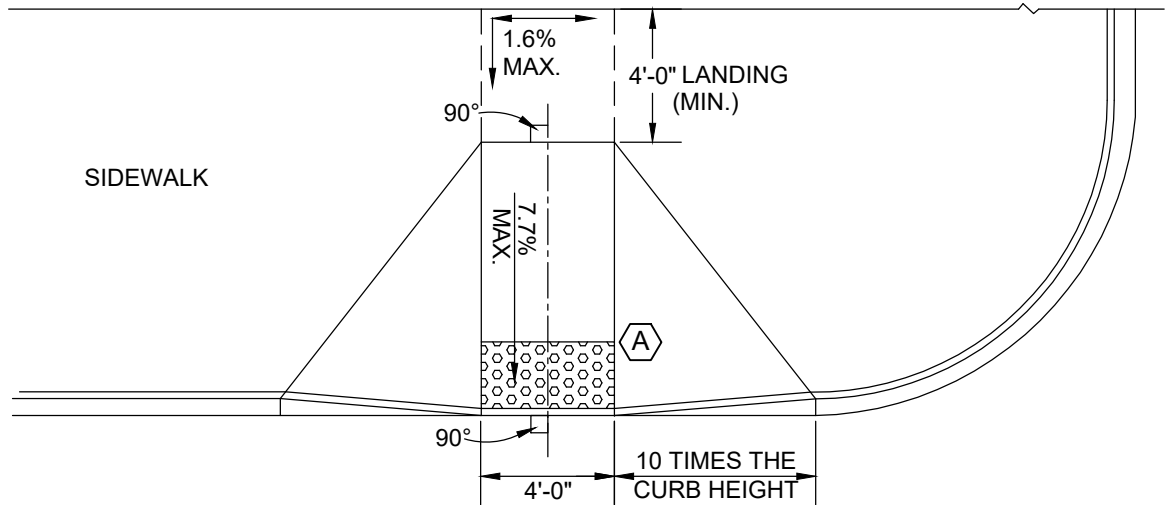

CODED NOTES:

(A) SEE SHEETS 2 AND 3 FOR DETECTABLE WARNING DETAILS

GENERAL NOTES:

SEE SHEETS 2 AND 3 FOR ADDITIONAL DETAILED INFORMATION.

CURB RAMP TYPE A

CITY OF COLUMBUS, OHIO
DEPARTMENT OF PUBLIC SERVICE
DIVISION OF DESIGN AND CONSTRUCTION

STD DWG

2319

07/01/2024

SHT 4 OF 23

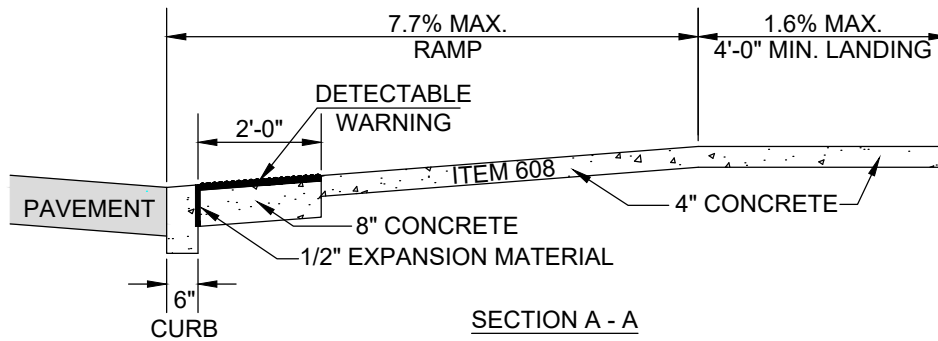
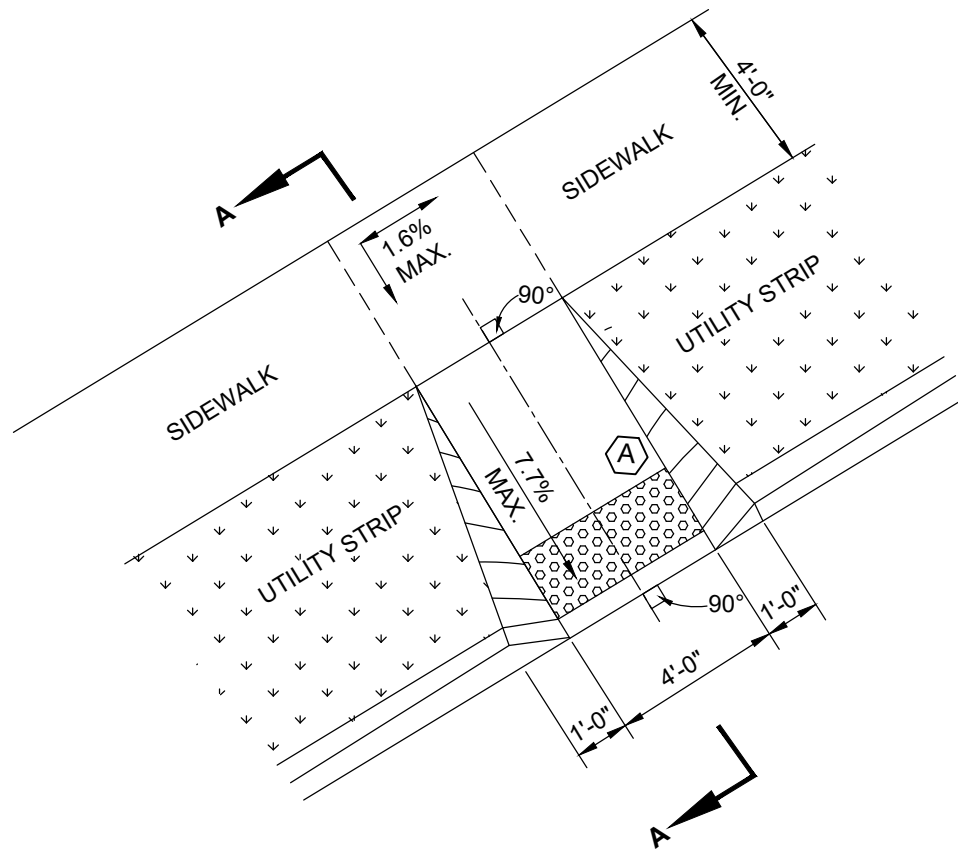

CODING NOTES:

(A) SEE SHEETS 2 AND 3 FOR DETECTABLE WARNING DETAILS

GENERAL NOTES:

SEE SHEETS 2 AND 3 FOR ADDITIONAL DETAILED INFORMATION.

CURB RAMP TYPE C

CITY OF COLUMBUS, OHIO
DEPARTMENT OF PUBLIC SERVICE
DIVISION OF DESIGN AND CONSTRUCTION

STD DWG

2319

07/01/2024

SHT 5 OF 23

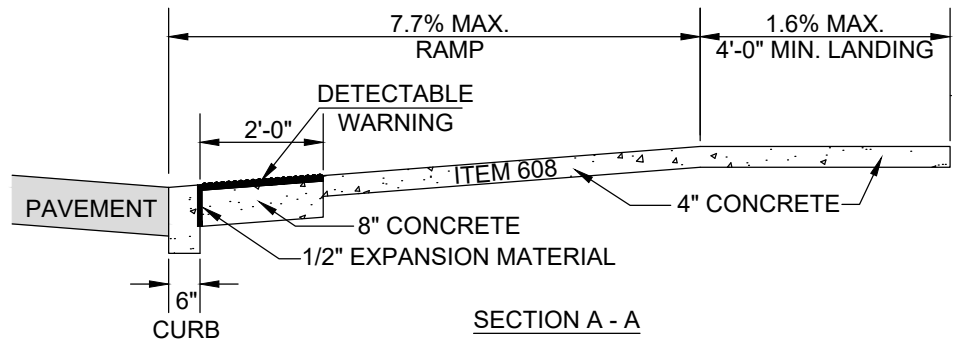
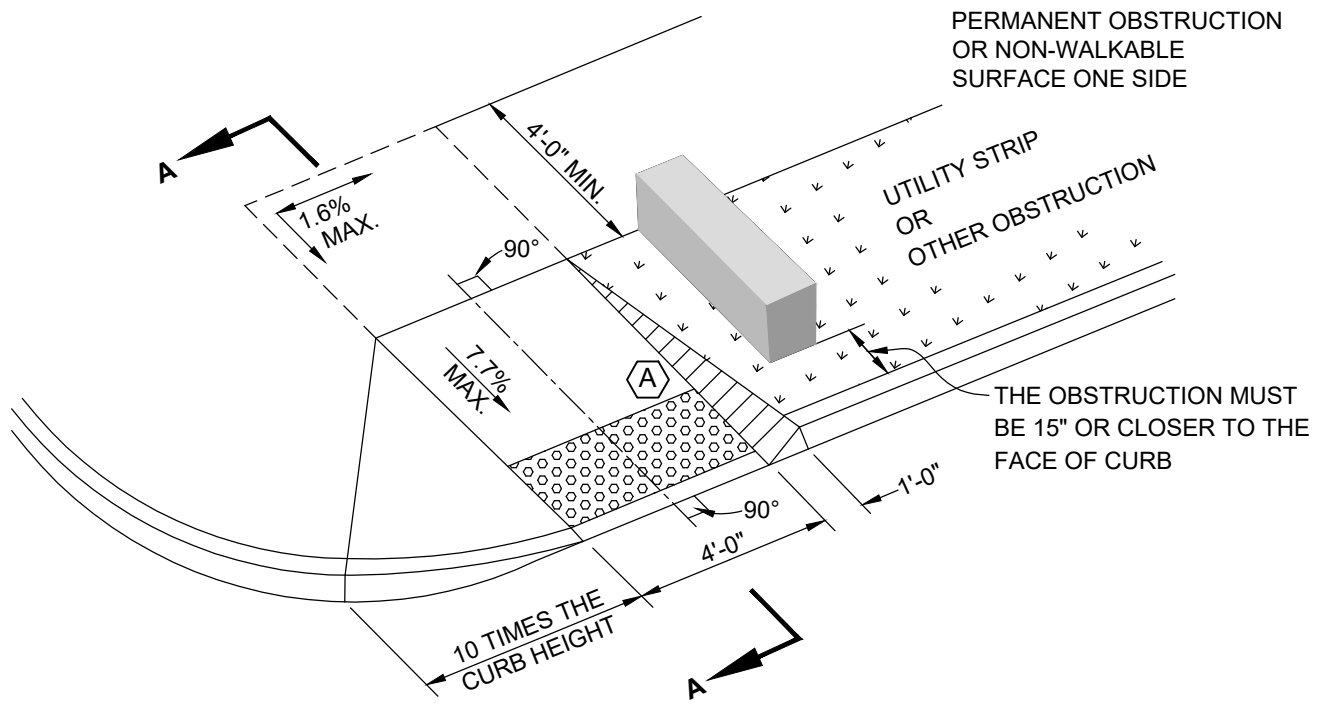

CODED NOTES:

(A) SEE SHEETS 2 AND 3 FOR DETECTABLE WARNING DETAILS

GENERAL NOTES:

SEE SHEETS 2 AND 3 FOR ADDITIONAL DETAILED INFORMATION.

CURB RAMP TYPE D

CITY OF COLUMBUS, OHIO
DEPARTMENT OF PUBLIC SERVICE
DIVISION OF DESIGN AND CONSTRUCTION

STD DWG

2319

07/01/2024

SHT 6 OF 23

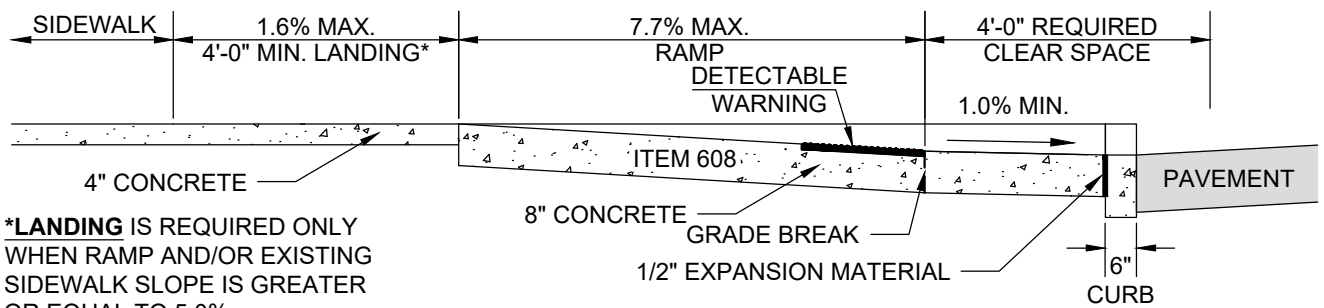
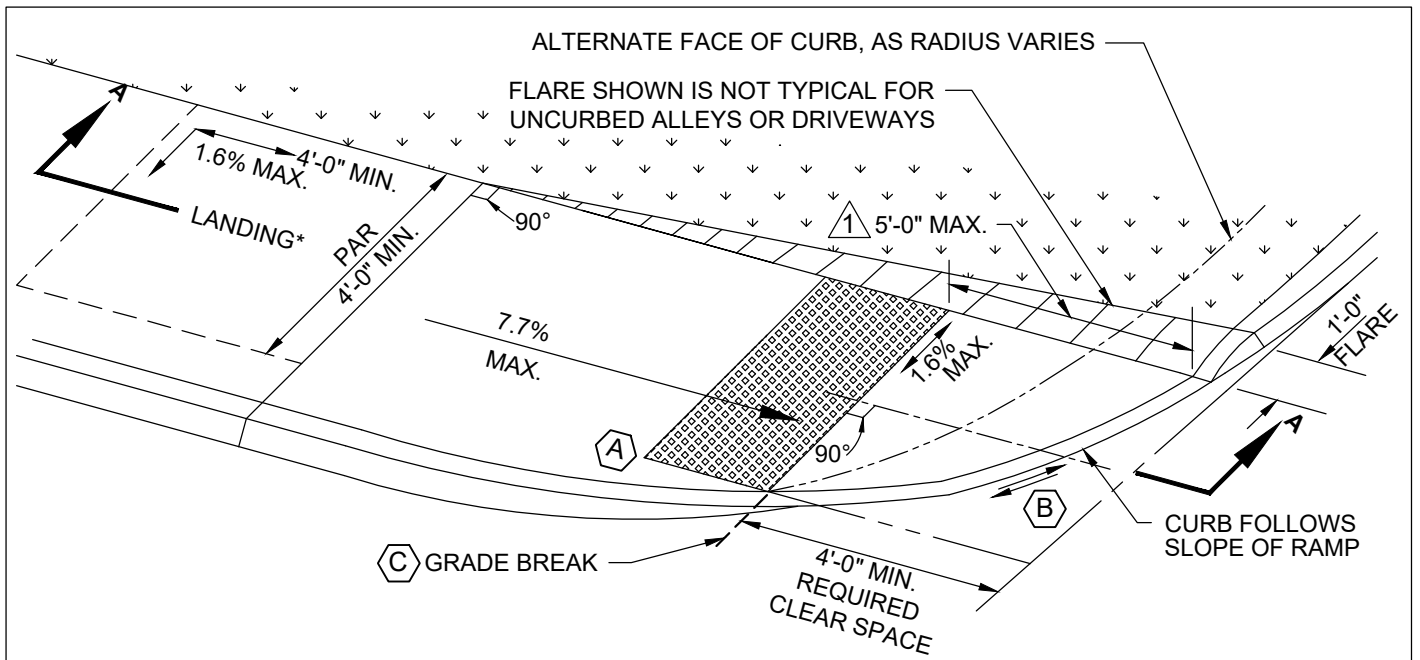

*LANDING IS REQUIRED ONLY WHEN RAMP AND/OR EXISTING SIDEWALK SLOPE IS GREATER OR EQUAL TO 5.0%

SECTION A-A

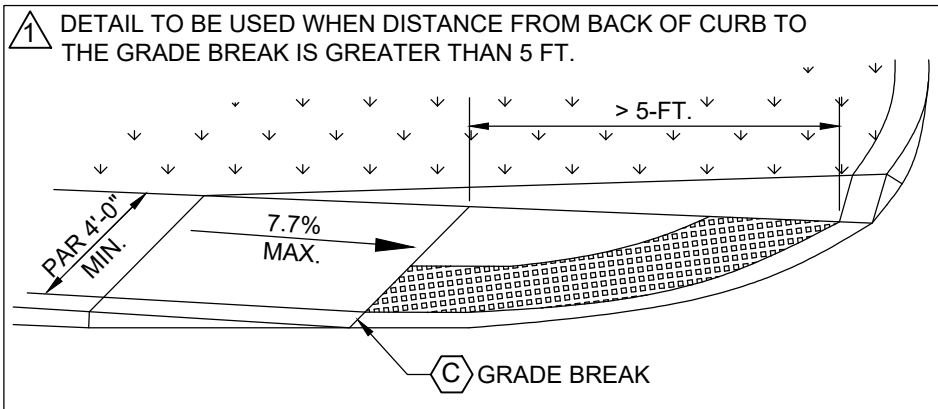

CODING NOTES:

- (A) SEE SHEETS 2 AND 3 FOR DETECTABLE WARNING DETAILS
- (B) PROVIDE POSITIVE DRAINAGE ALONG CURBLINE, SHOULD BE 1.0% MINIMUM SLOPE
- (C) WHERE THE DISTANCE FROM EITHER END OF THE BOTTOM OF THE GRADE BREAK TO THE BACK OF CURB IS GREATER THAN 5-FT, THE DETECTABLE WARNING SHALL BE PLACED AT THE BACK OF CURB

GENERAL NOTES:

1. SEE SHEETS 2 AND 3 FOR ADDITIONAL DETAILED INFORMATION.
2. THE EDGE OF THE CURB WITHIN THE CLEAR SPACE SHALL BE FLUSH WITH THE EDGE OF THE ADJACENT PAVEMENT AND GUTTER.

CURB RAMP TYPE G

CITY OF COLUMBUS, OHIO
DEPARTMENT OF PUBLIC SERVICE
DIVISION OF DESIGN AND CONSTRUCTION

STD DWG

2319

07/01/2024

SHT 7 OF 23

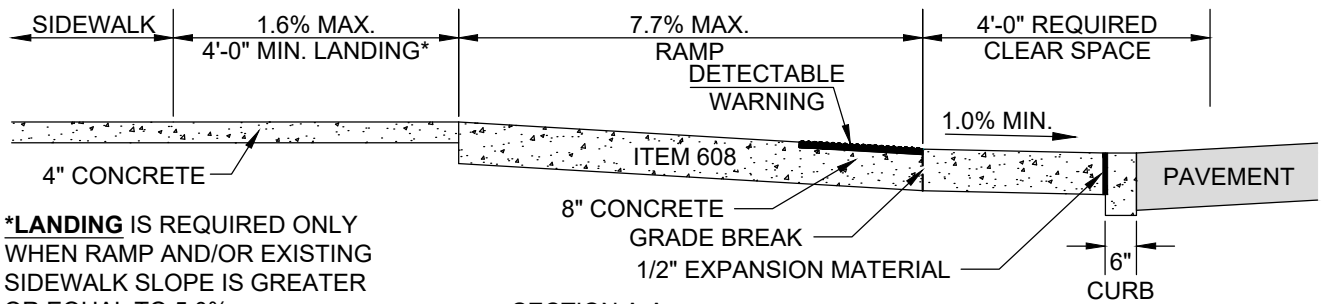
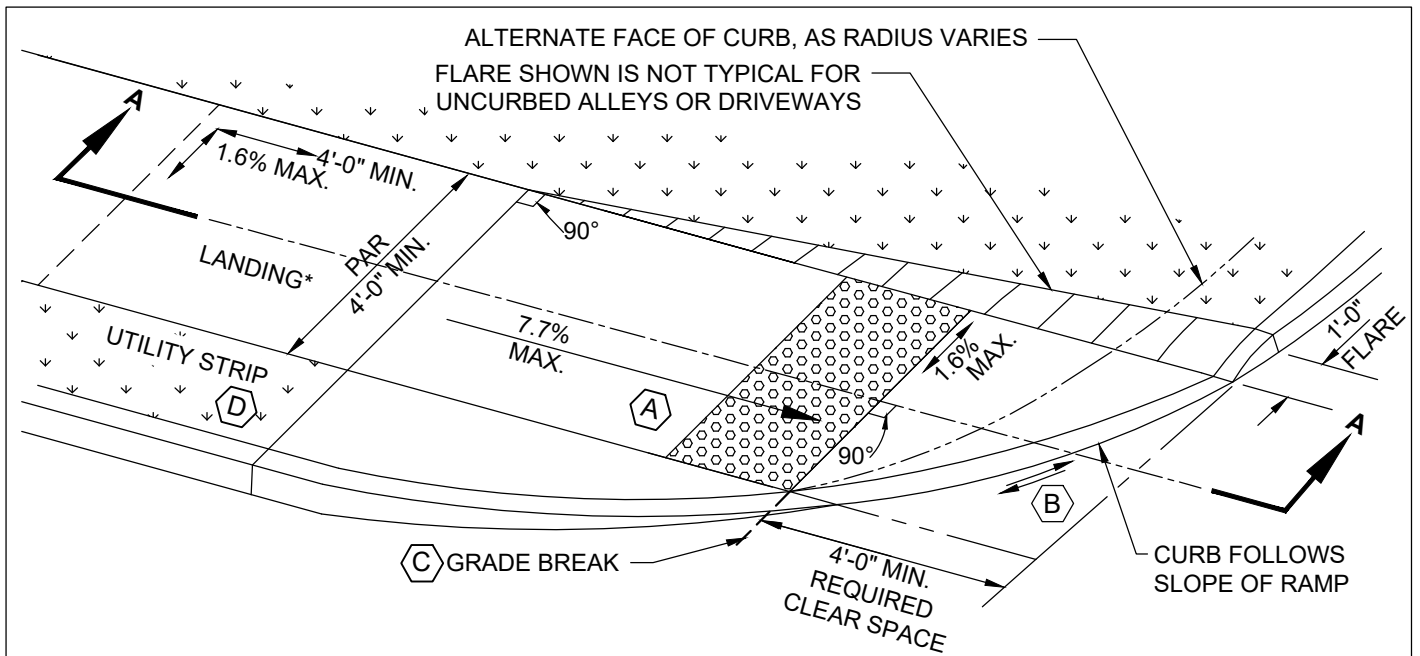

*LANDING IS REQUIRED ONLY WHEN RAMP AND/OR EXISTING SIDEWALK SLOPE IS GREATER OR EQUAL TO 5.0%

CODED NOTES:

- (A) SEE SHEETS 2 AND 3 FOR DETECTABLE WARNING DETAILS
- (B) PROVIDE POSITIVE DRAINAGE ALONG CURBLINE, SHOULD BE 1.0% MINIMUM SLOPE
- (C) WHERE THE DISTANCE FROM EITHER END OF THE BOTTOM OF THE GRADE BREAK TO THE BACK OF CURB IS GREATER THAN 5-FT, THE DETECTABLE WARNING SHALL BE PLACED AT THE BACK OF CURB
- (D) FOR THE LENGTH OF THE RAMP, THE UTILITY STRIP MAY BE REMOVED AND REPLACED WITH 8" CONCRETE (ITEM 608), PROVIDED THE UTILITY STRIP IS NO WIDER THAN 2-FT. FOR GREATER WIDTHS, CITY APPROVAL IS REQUIRED

GENERAL NOTES:

1. SEE SHEETS 2 AND 3 FOR ADDITIONAL DETAILED INFORMATION.
2. THE EDGE OF THE CURB WITHIN THE CLEAR SPACE SHALL BE FLUSH WITH THE EDGE OF THE ADJACENT PAVEMENT AND GUTTER.

CURB RAMP TYPE H

CITY OF COLUMBUS, OHIO
DEPARTMENT OF PUBLIC SERVICE
DIVISION OF DESIGN AND CONSTRUCTION

STD DWG

2319

07/01/2024

SHT 8 OF 23

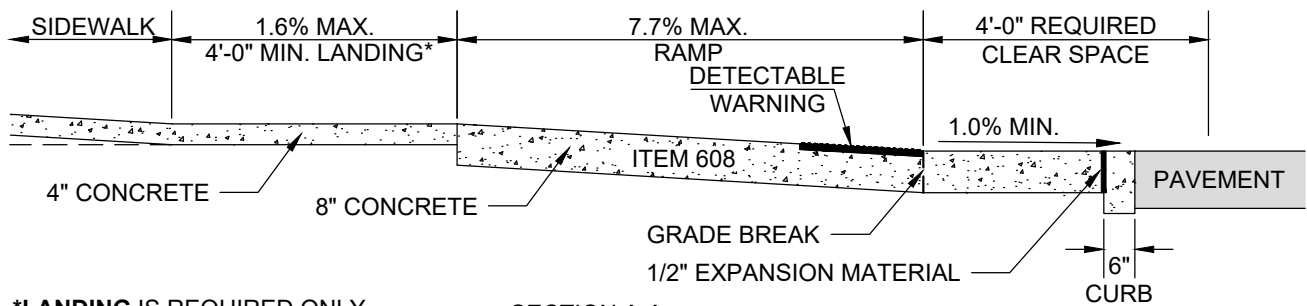
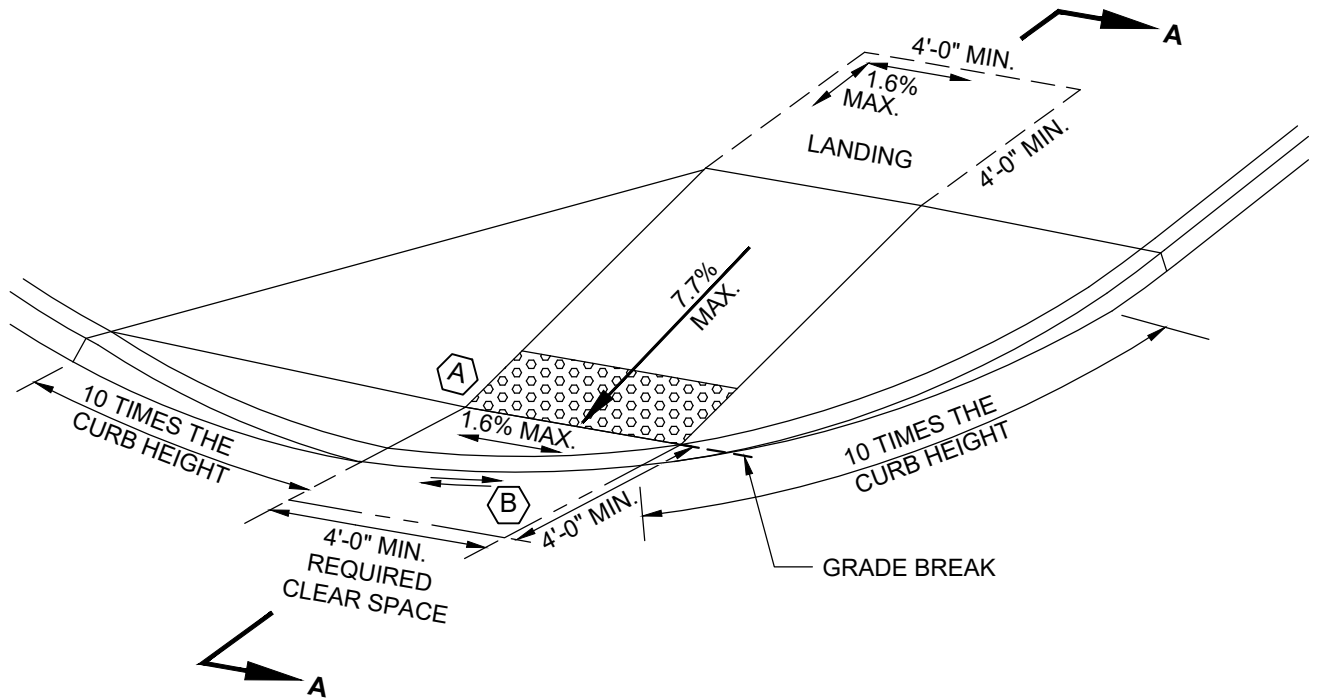

***LANDING** IS REQUIRED ONLY WHEN RAMP AND/OR EXISTING SIDEWALK SLOPE IS GREATER OR EQUAL TO 5.0%

SECTION A-A

CODING NOTES:

(A) SEE SHEETS 2 AND 3 FOR DETECTABLE WARNING DETAILS

(B) PROVIDE POSITIVE DRAINAGE ALONG CURBLINE, SHOULD BE 1.0% MINIMUM SLOPE

GENERAL NOTES:

- SEE SHEETS 2 AND 3 FOR ADDITIONAL DETAILED INFORMATION.
- THE EDGE OF THE CURB WITHIN THE CLEAR SPACE SHALL BE FLUSH WITH THE EDGE OF THE ADJACENT PAVEMENT AND GUTTER.

CURB RAMP TYPE J

CITY OF COLUMBUS, OHIO
DEPARTMENT OF PUBLIC SERVICE
DIVISION OF DESIGN AND CONSTRUCTION

STD DWG

2319

07/01/2024

SHT 9 OF 23

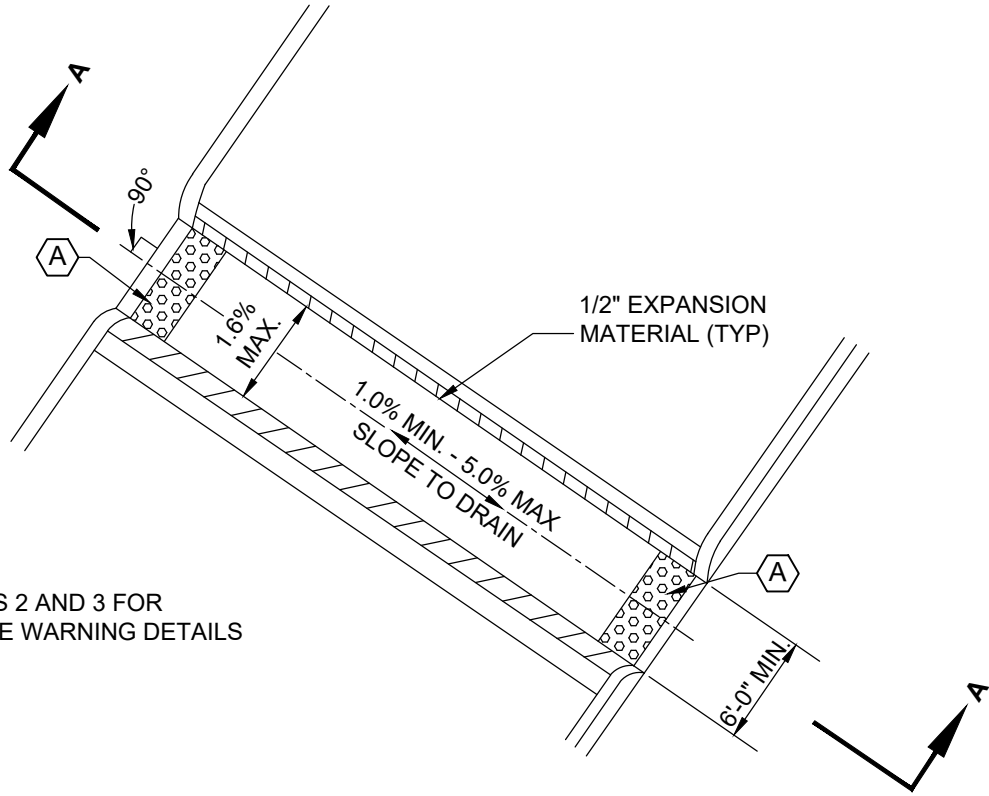

CODED NOTES:

(A) SEE SHEETS 2 AND 3 FOR DETECTABLE WARNING DETAILS

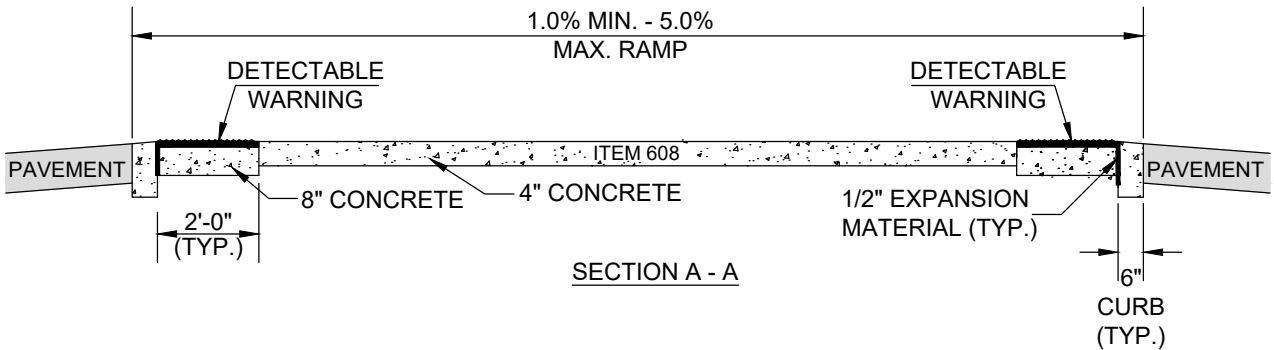

GENERAL NOTES:

1. SEE SHEETS 2 AND 3 FOR ADDITIONAL DETAILED INFORMATION.
2. RAMP L-1 SHALL BE USED IN ALL CIRCUMSTANCES WHERE NOT PROHIBITED BY DRAINAGE ISSUES. AN L-1 RAMP SHOULD NOT BE PLACED IN A WAY THAT WOULD CONVEY THE CURB FLOW OF WATER THROUGH THE MEDIAN PASS-THROUGH. WHERE THE ROADWAY CROSS-SLOPE DIRECTS WATER TOWARDS THE MEDIAN AND FLOWS THROUGH THE GUTTER LINE ADJACENT TO THE PASS-THROUGH, USE AN L-2 RAMP.
3. MEDIANS / ISLANDS WITHIN COMMERCIAL DRIVES REQUIRE DETECTABLE WARNINGS ONLY WHEN OPPOSING CURB RAMPS REQUIRE DETECTABLE WARNINGS. (SEE SHEET 3 OF 23, NOTE 13)

CURB RAMP TYPE L-1

CITY OF COLUMBUS, OHIO
DEPARTMENT OF PUBLIC SERVICE
DIVISION OF DESIGN AND CONSTRUCTION

STD DWG

2319

07/01/2024

SHT 10 OF 23

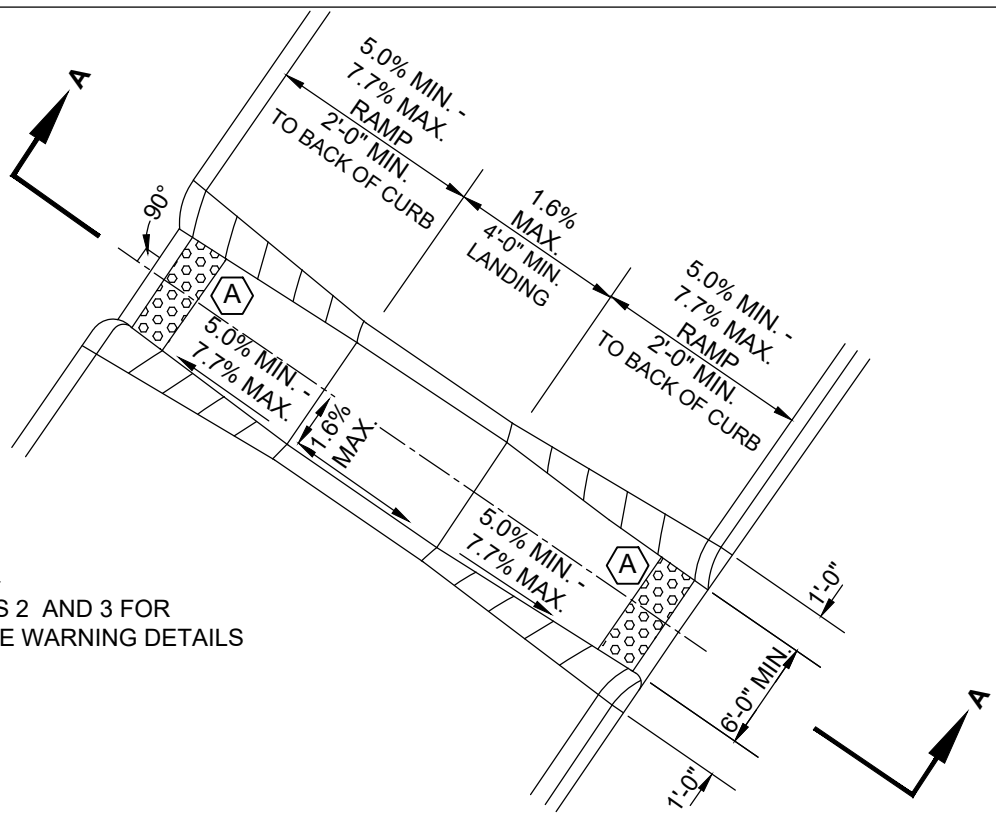

CODED NOTES:

(A) SEE SHEETS 2 AND 3 FOR DETECTABLE WARNING DETAILS

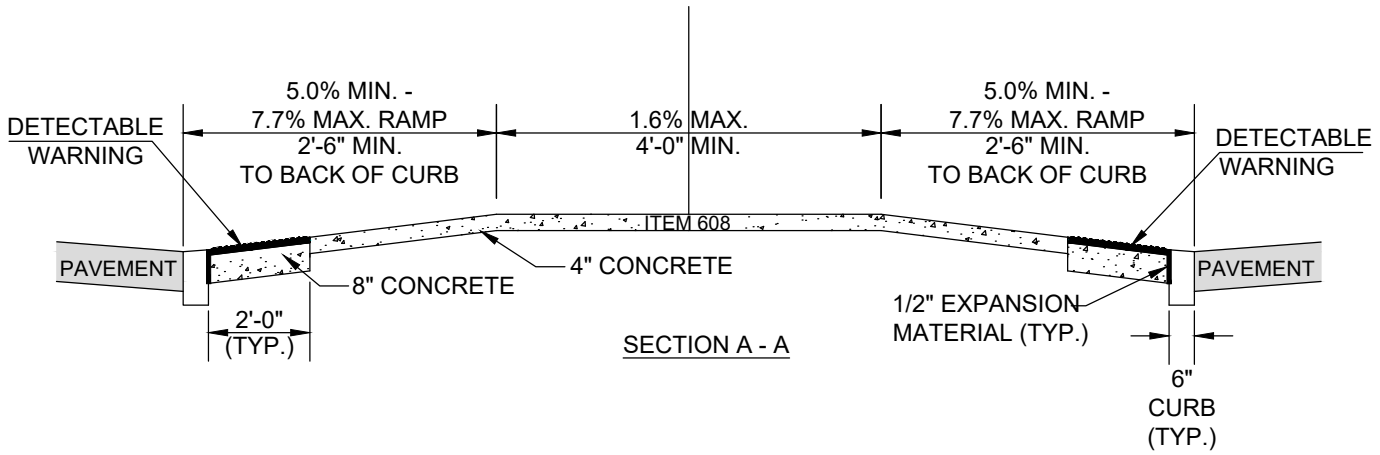

GENERAL NOTES:

1. SEE SHEETS 2 AND 3 FOR ADDITIONAL DETAILED INFORMATION.
2. MEDIANS / ISLANDS WITHIN COMMERCIAL DRIVES REQUIRE DETECTABLE WARNINGS ONLY WHEN OPPOSING CURB RAMPS REQUIRE DETECTABLE WARNINGS. (SEE SHEET 3 OF 23, NOTE 13).
3. TYPE L-2 RAMPS ARE ONLY TO BE INSTALLED WHEN IT IS NOT POSSIBLE TO INSTALL A TYPE L-1 RAMP DUE TO DRAINAGE ISSUES.
4. TYPE L-2 RAMPS CAN ONLY BE USED ON MEDIANS 8 FEET WIDE OR MORE.

<h1 style="margin: 0;">CURB RAMP TYPE L-2</h1>	
CITY OF COLUMBUS, OHIO DEPARTMENT OF PUBLIC SERVICE DIVISION OF DESIGN AND CONSTRUCTION	STD DWG 2319 07/01/2024 SHT 11 OF 23

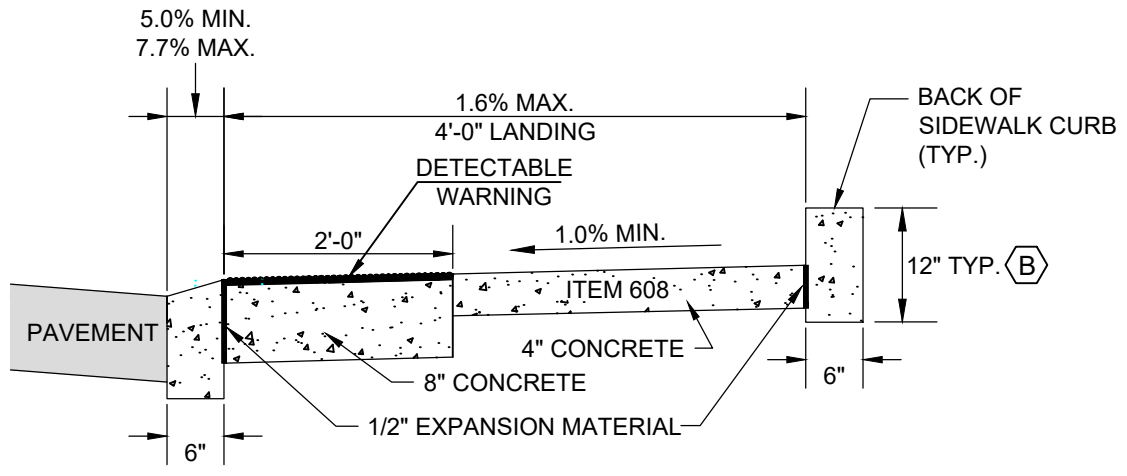
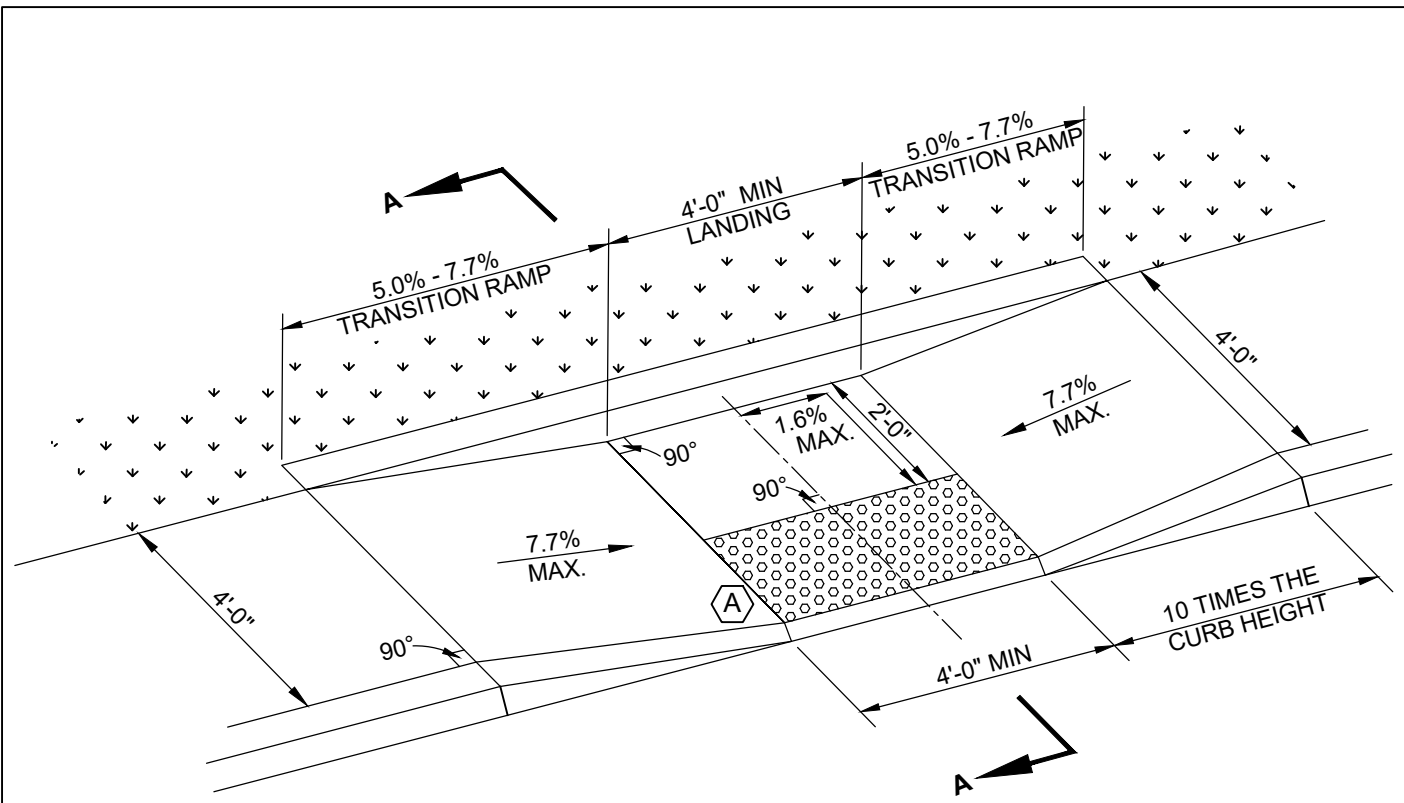

SECTION A-A

CODED NOTES:

- (A) SEE SHEETS 2 AND 3 FOR DETECTABLE WARNING DETAILS
- (B) EXPOSED REVEAL MUST EQUAL BURIED DEPTH; 12" MAXIMUM REVEAL; FOR ADDITIONAL DETAILS SEE CURB WALL SPECIFICATION

GENERAL NOTES:

SEE SHEETS 2 AND 3 FOR ADDITIONAL DETAILED INFORMATION.

<h2 style="margin: 0;">CURB RAMP TYPE P-4</h2>	
CITY OF COLUMBUS, OHIO DEPARTMENT OF PUBLIC SERVICE DIVISION OF DESIGN AND CONSTRUCTION	STD DWG 2319 07/01/2024 SHT 12 OF 23

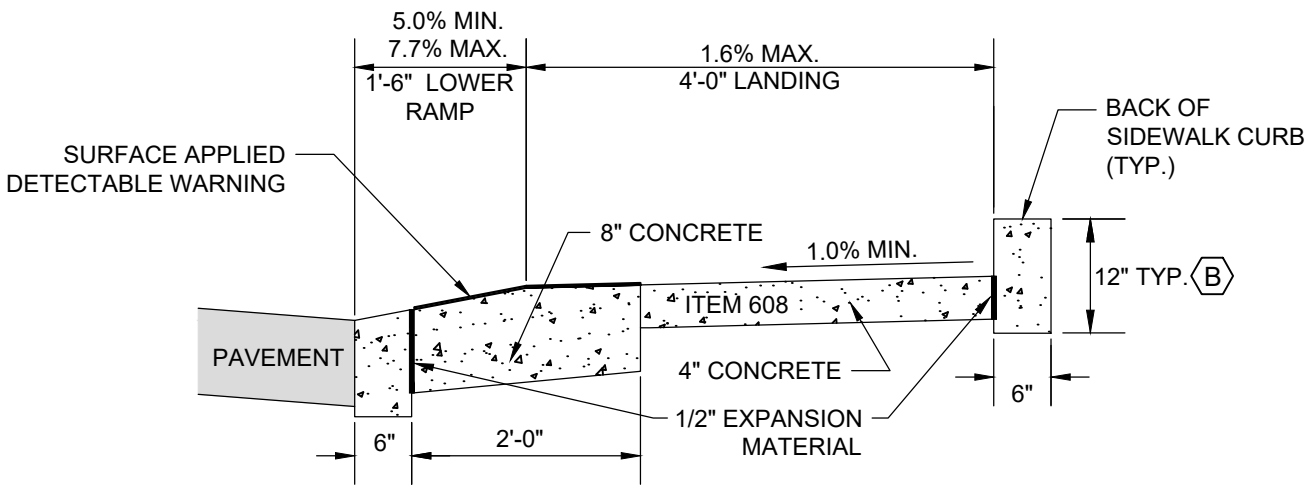
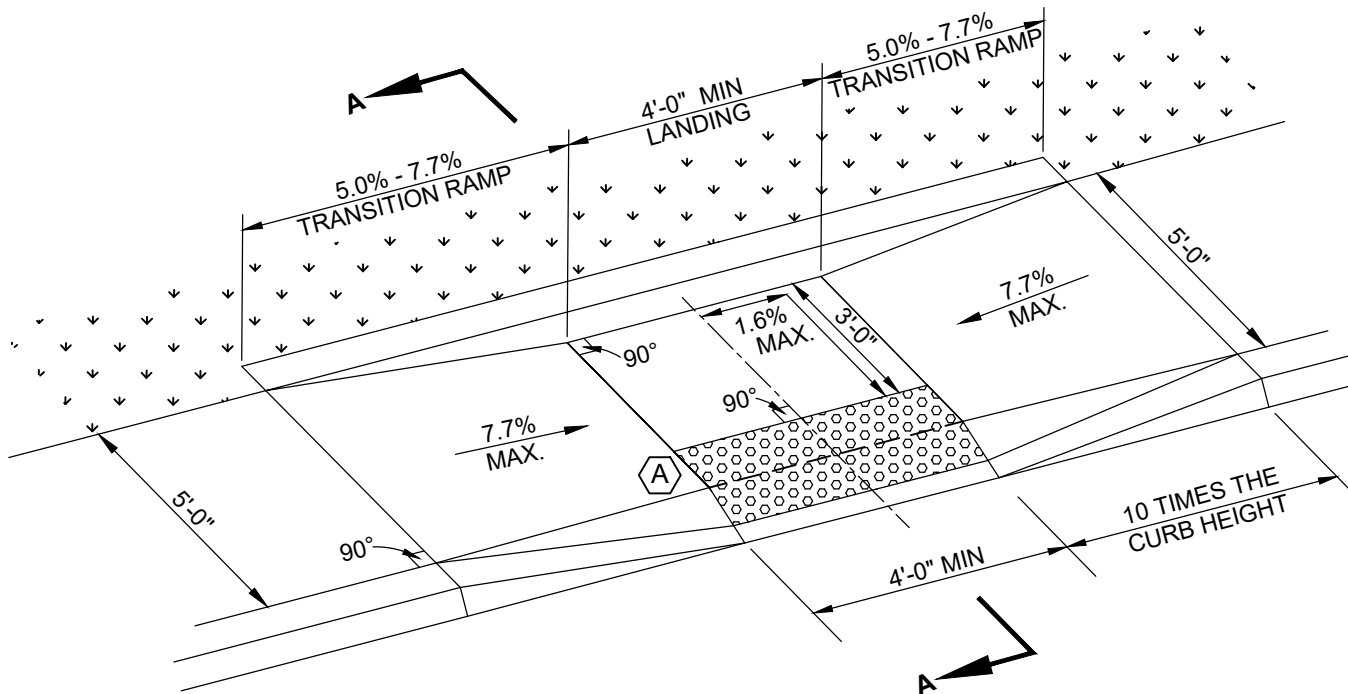

SECTION A-A

CODED NOTES:

- (A) SEE SHEETS 2 AND 3 FOR DETECTABLE WARNING DETAILS
- (B) EXPOSED REVEAL MUST EQUAL BURIED DEPTH; 12" MAXIMUM REVEAL; FOR ADDITIONAL DETAILS SEE CURB WALL SPECIFICATION

GENERAL NOTES:

SEE SHEETS 2 AND 3 FOR ADDITIONAL DETAILED INFORMATION.

<h2 style="margin: 0;">CURB RAMP TYPE P-5</h2>	
CITY OF COLUMBUS, OHIO DEPARTMENT OF PUBLIC SERVICE DIVISION OF DESIGN AND CONSTRUCTION	STD DWG <h1 style="margin: 0;">2319</h1>
07/01/2024 SHT 13 OF 23	

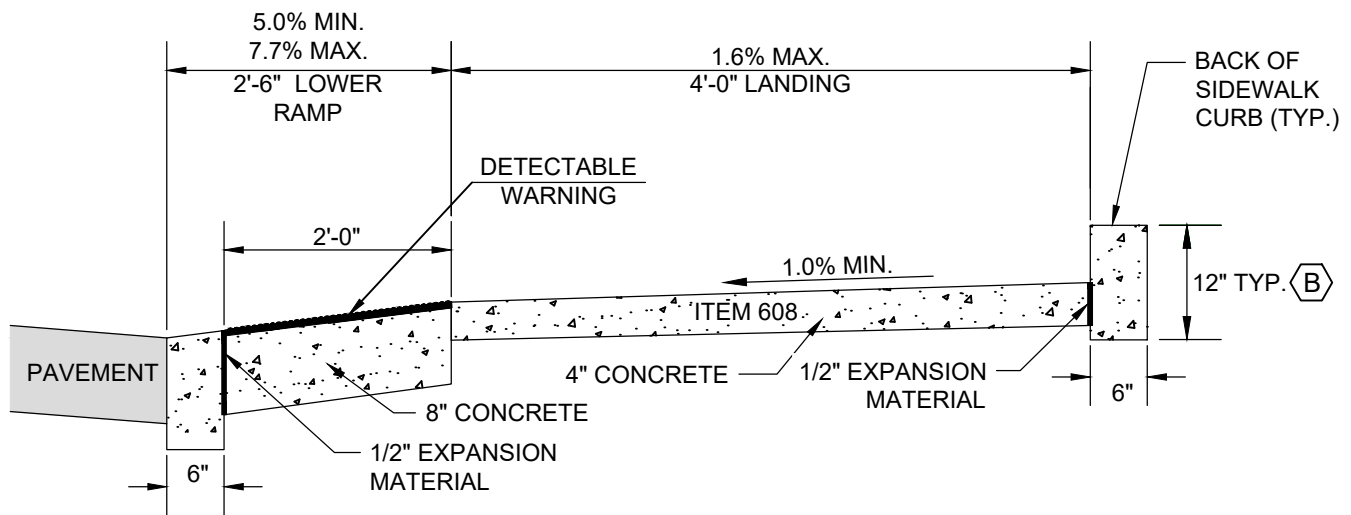
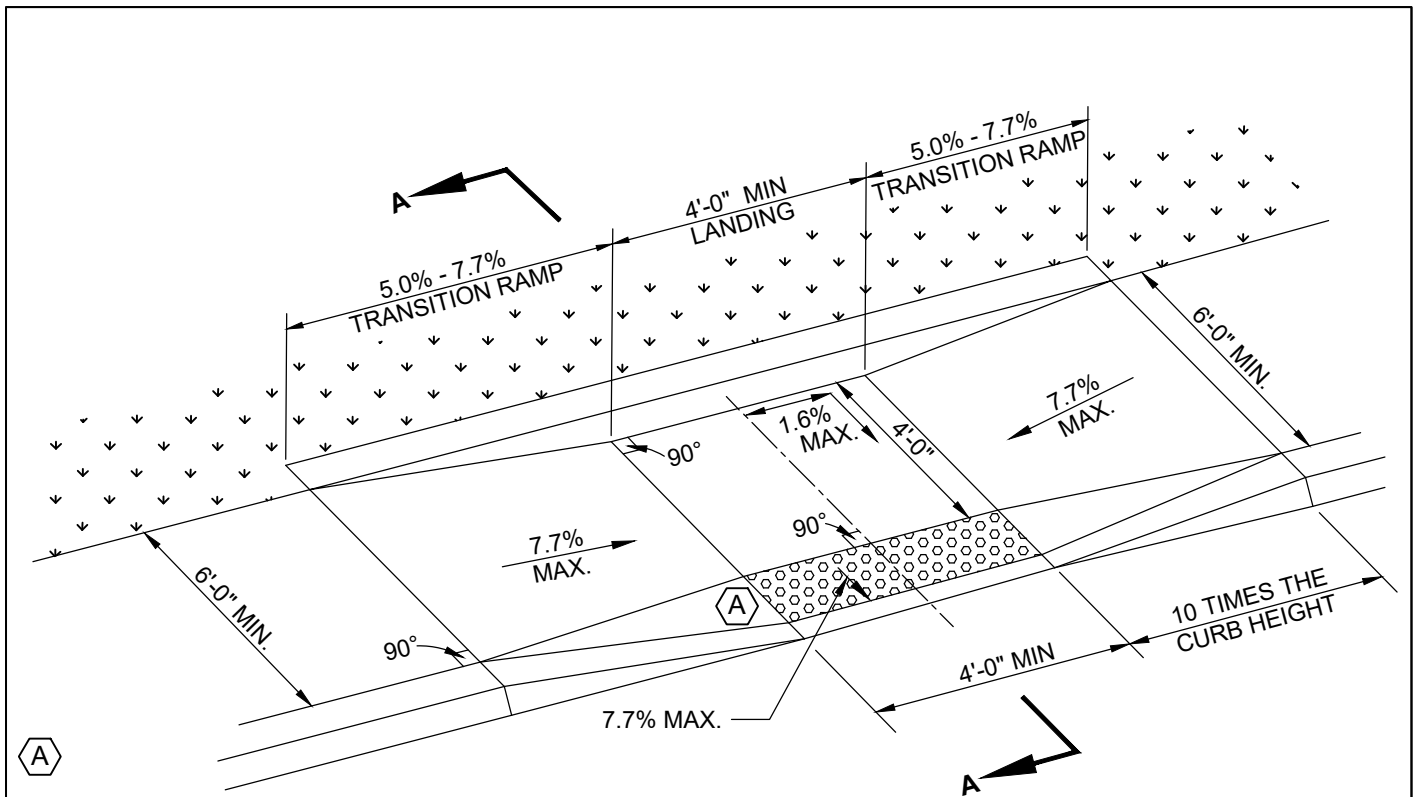

SECTION A-A

CODING NOTES:

- (A)** SEE SHEETS 2 AND 3 FOR DETECTABLE WARNING DETAILS
- (B)** EXPOSED REVEAL MUST EQUAL BURIED DEPTH; 12" MAXIMUM REVEAL; FOR ADDITIONAL DETAILS SEE CURB WALL SPECIFICATION

GENERAL NOTES:

SEE SHEETS 2 AND 3 FOR ADDITIONAL DETAILED INFORMATION.

<h2 style="margin: 0;">CURB RAMP TYPE P-6</h2>	
CITY OF COLUMBUS, OHIO DEPARTMENT OF PUBLIC SERVICE DIVISION OF DESIGN AND CONSTRUCTION	STD DWG <h3 style="margin: 0;">2319</h3>
07/01/2024 SHT 14 OF 23	

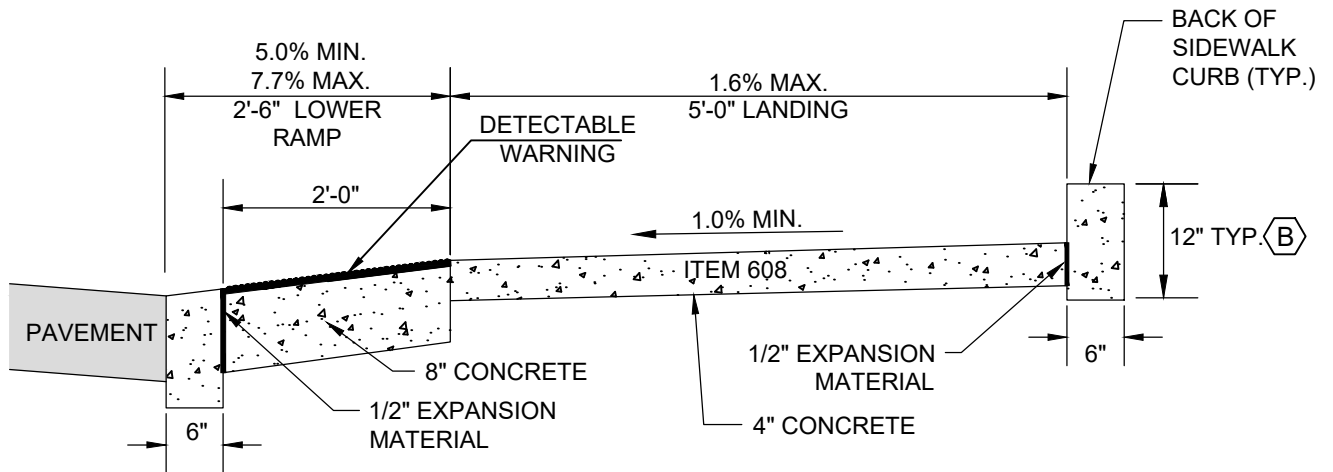
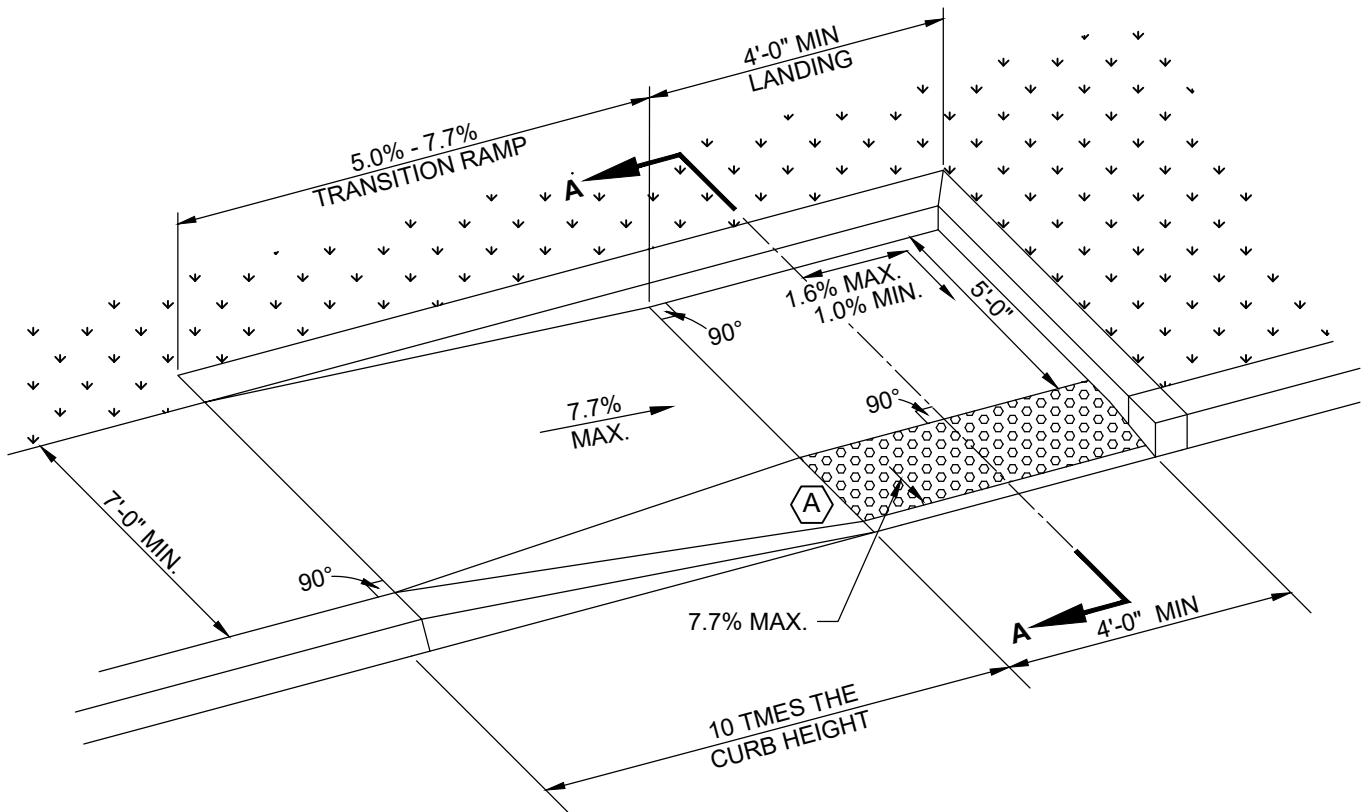

SECTION A-A

CODED NOTES:

(A) SEE SHEETS 2 AND 3 FOR DETECTABLE WARNING DETAILS

(B) EXPOSED REVEAL MUST EQUAL BURIED DEPTH; 12" MAXIMUM REVEAL; FOR ADDITIONAL DETAILS SEE CURB WALL SPECIFICATION

GENERAL NOTES:

SEE SHEETS 2 AND 3 FOR ADDITIONAL DETAILED INFORMATION.

CURB RAMP TYPE P-7

CITY OF COLUMBUS, OHIO
DEPARTMENT OF PUBLIC SERVICE
DIVISION OF DESIGN AND CONSTRUCTION

STD DWG

2319

07/01/2024

SHT 15 OF 23

PEDESTRIAN PAD (PP) TYPE 1 CONDITION-CONNECTED SEPARATED FROM CURB

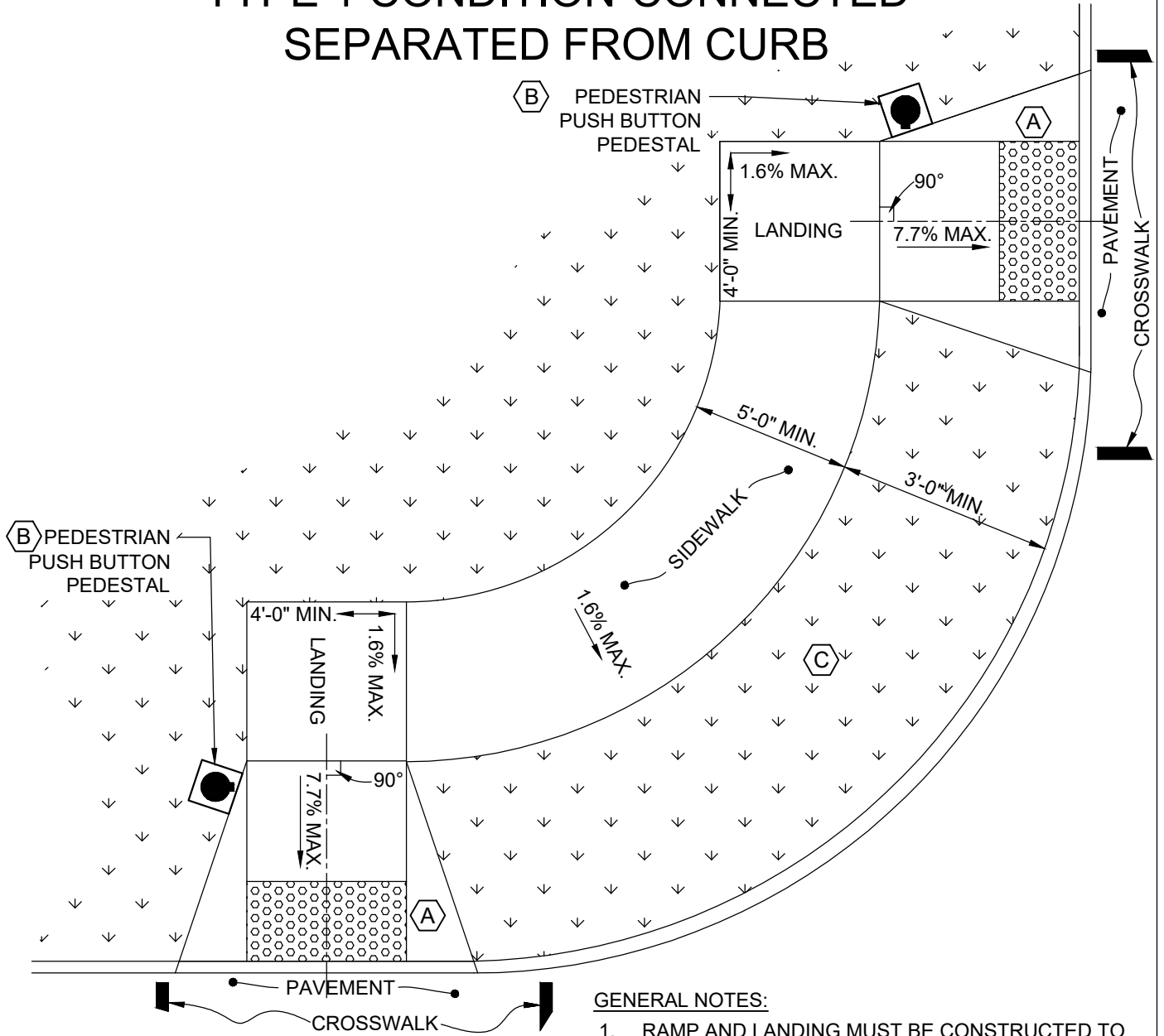

CODED NOTES:

- (A)** USE 1-FT FLARES ON CURBED ROADWAY. ON UNCURBED ROADWAY RAMP SHALL BE CONSTRUCTED WITHOUT FLARES, SEE SHEET 22 FOR DETECTABLE WARNING PLACEMENT DETAILS. THE FRONT TWO FEET OF THE RAMP AND FLARES SHALL BE CONSTRUCTED USING CONCRETE 8" THICK AND TRANSITIONING TO 4" CONCRETE FURTHER THAN 2 FEET FROM THE BACK OF THE CURB
- (B)** ORIENTATION/LOCATION OF PUSH BUTTON/PEDESTAL TO BE PER POLICY
- (C)** IF UTILITY STRIP IS LESS THAN 3-FT, SIDEWALK SHALL BE CONSTRUCTED ADJACENT TO CURB, SEE PP-2

GENERAL NOTES:

1. RAMP AND LANDING MUST BE CONSTRUCTED TO DRAIN, TYPICALLY TOWARDS THE ROADWAY, BUT MAY VARY BASED ON EXISTING TOPOGRAPHY. WEEP HOLES ARE NOT PERMITTED FOR DRAINAGE.
2. SEE SHEET 2 FOR ADDITIONAL DETAILED INFORMATION.

CURB RAMP TYPE PP-1

CITY OF COLUMBUS, OHIO
DEPARTMENT OF PUBLIC SERVICE
DIVISION OF DESIGN AND CONSTRUCTION

STD DWG
2319
07/01/2024
SHT 16 OF 24

PEDESTRIAN PAD (PP) TYPE 2 CONDITION-CONNECTED ADJACENT TO CURB

GENERAL NOTES:

1. RAMP AND LANDING MUST BE CONSTRUCTED TO DRAIN, TYPICALLY TOWARDS THE ROADWAY, BUT MAY VARY BASED ON EXISTING TOPOGRAPHY. WEEP HOLES ARE NOT PERMITTED FOR DRAINAGE.
2. SEE SHEETS 2 AND 3 FOR ADDITIONAL DETAILED INFORMATION.

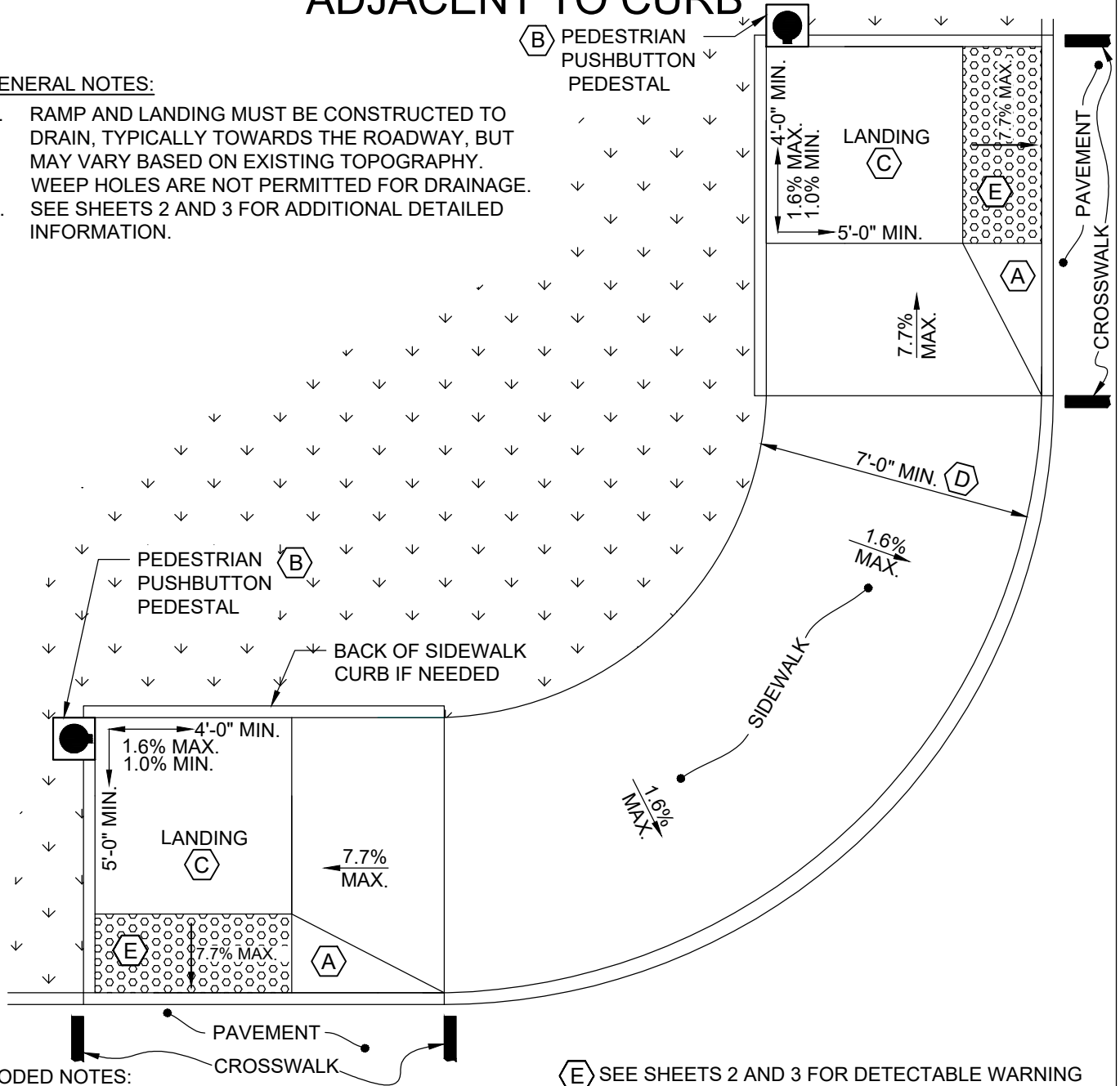

CODED NOTES:

- (A) SEE SHEET 2 FOR DETECTABLE WARNING DETAILS. THE FRONT TWO FEET OF THE RAMP AND FLARES SHALL BE CONSTRUCTED USING CONCRETE 8" THICK AND 4" CONCRETE FURTHER THAN 2 FEET FROM THE BACK OF THE CURB
- (B) ORIENTATION/LOCATION OF PUSH BUTTON/PEDESTAL TO BE PER CITY OF COLUMBUS ADA RULES AND REGULATIONS.
- (C) WIDTH OF THE RAMP AND LANDING MAY BE REDUCED TO 4-FT WHERE NO CURB WALL IS PRESENT
- (D) SIDEWALK WIDTH MAY BE REDUCED TO 5-FT MIN. WHEN CONSTRAINED. SEE RAMP TYPE P-4, SECTION A-A FOR RAMP AND LANDING

(E) SEE SHEETS 2 AND 3 FOR DETECTABLE WARNING DETAILS

CURB RAMP TYPE PP-2

CITY OF COLUMBUS, OHIO
DEPARTMENT OF PUBLIC SERVICE
DIVISION OF DESIGN AND CONSTRUCTION

STD DWG

2319

07/01/2024

SHT 17 OF 23

PEDESTRIAN PAD (PP) TYPE 3 CONDITION-SHARED CURB IS PRESENT

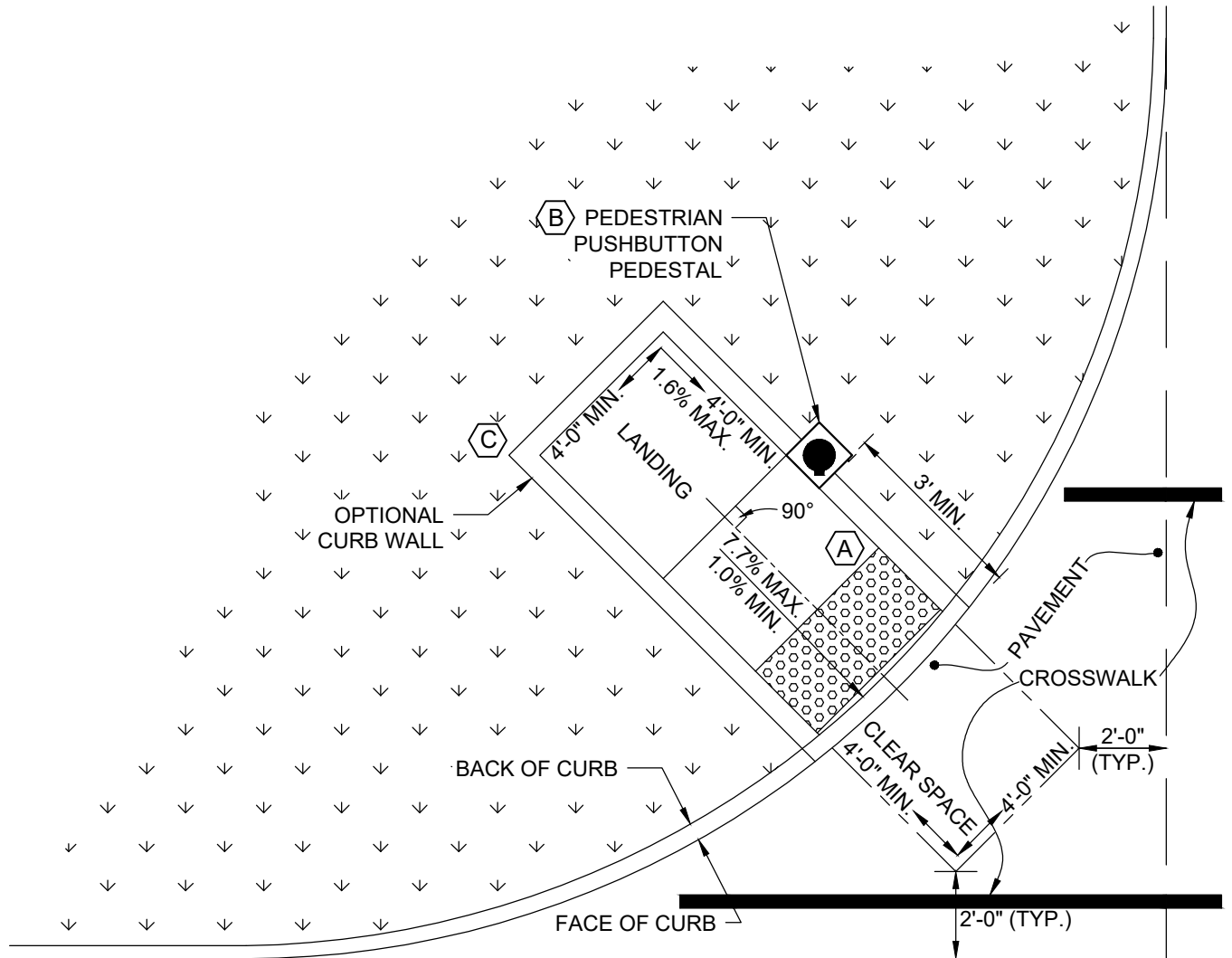

CODED NOTES:

- (A) SEE SHEETS 2 AND 3 FOR DETECTABLE WARNING DETAILS. THE FRONT TWO FEET OF THE RAMP AND FLARES SHALL BE CONSTRUCTED USING CONCRETE 8" THICK TO 4" CONCRETE FURTHER THAN 2 FEET FROM THE BACK OF THE CURB
- (B) ORIENTATION/LOCATION OF PUSH BUTTON/PEDESTAL TO BE PER CITY OF COLUMBUS ADA RULES AND REGULATIONS
- (C) CURB WALL MAY BE NECESSARY BASED ON EXISTING TOPOGRAPHY.

GENERAL NOTES:

1. RAMP AND LANDING MUST BE CONSTRUCTED TO DRAIN, TYPICALLY TOWARDS THE ROADWAY, BUT MAY VARY BASED ON EXISTING TOPOGRAPHY. WEEP HOLES ARE NOT PERMITTED FOR DRAINAGE.
2. SEE SHEETS 2 AND 3 FOR ADDITIONAL DETAILED INFORMATION.

<h2 style="margin: 0;">CURB RAMP TYPE PP-3</h2>	
<p style="text-align: center; font-size: small;">CITY OF COLUMBUS, OHIO DEPARTMENT OF PUBLIC SERVICE DIVISION OF DESIGN AND CONSTRUCTION</p>	<p style="font-weight: bold; font-size: large;">STD DWG 2319</p>
<p style="text-align: right; font-size: x-small;">07/01/2024</p>	
<p style="text-align: right; font-size: x-small;">SHT 18 OF 23</p>	

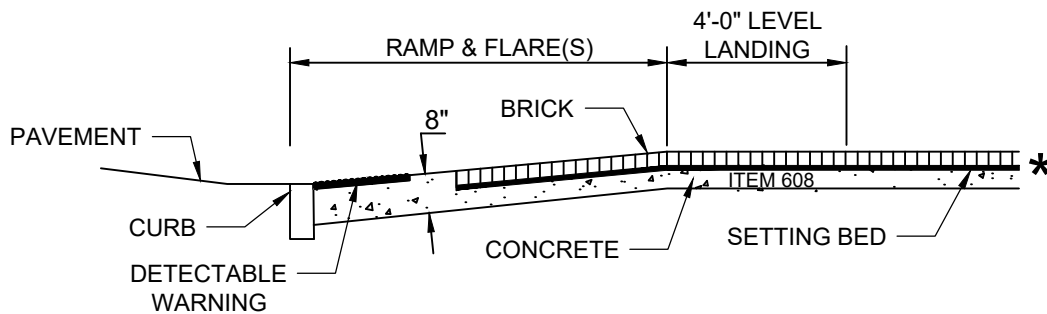
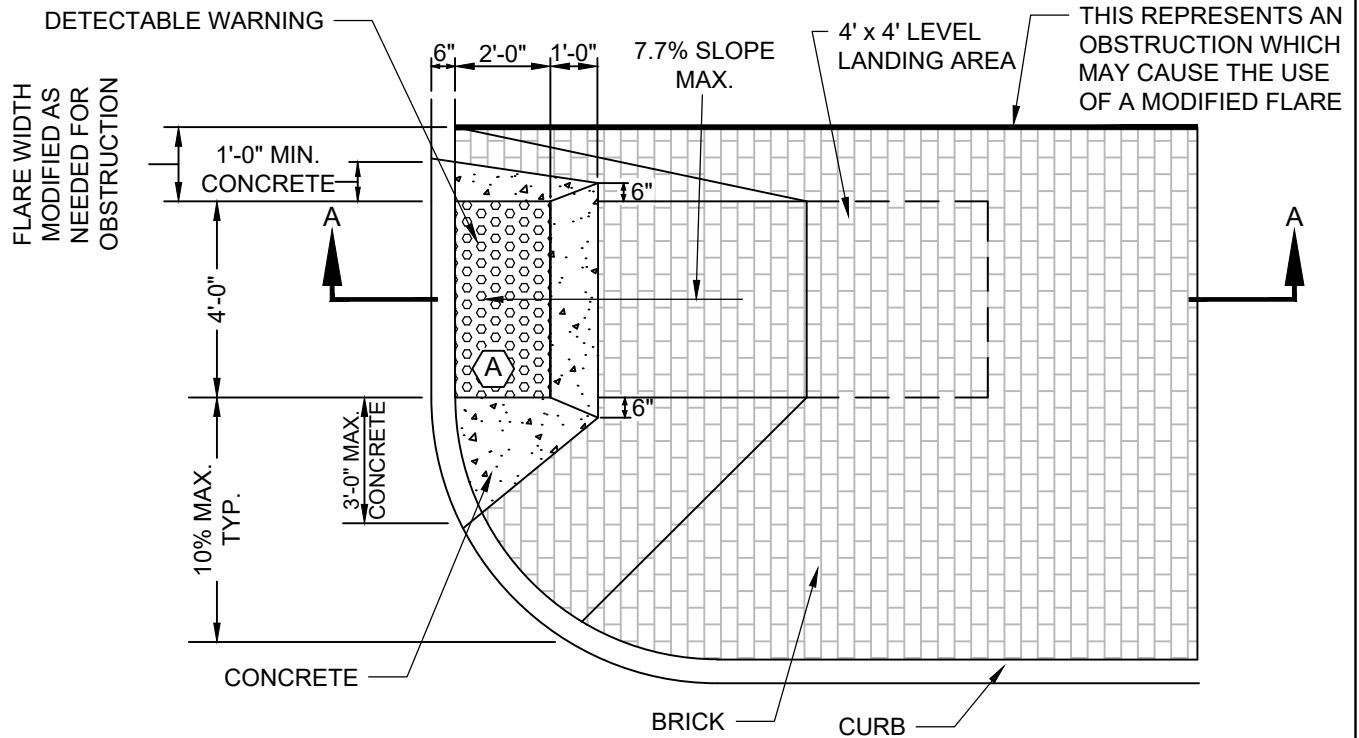

SECTION A-A

1. WRITTEN APPROVAL FROM THE CITY ENGINEER OR AN AUTHORIZED REPRESENTATIVE SHALL BE OBTAINED PRIOR TO THE DESIGN OR CONSTRUCTION OF GRANITE OR AN ALTERNATE MATERIAL CURB RAMP.
 2. ALONG WITH THE REQUIREMENT OF THIS SHEET FOR BRICK OR GRANITE CURB RAMPS, ALL OTHER APPLICABLE REQUIREMENTS OF 2319 SHALL BE FOLLOWED.
 3. BRICK OR GRANITE CURB RAMPS SHALL BE TYPED PER 2319. TYPICALLY TYPE A OR TYPE D WILL BE USED. ALL APPLICABLE DIMENSIONS AND REQUIREMENTS FOR THE SELECTED TYPE OF RAMP SHALL BE FOLLOWED.
 4. LONG FLARES WILL BE USED WHEREVER POSSIBLE. A MODIFIED FLARE SHALL BE USED WHEN AN OBSTRUCTION EXISTS.
 5. THE INSTALLATION OF THE BRICK OR GRANITE PAVERS SHALL BE DONE PER STD DWG 2301, BRICK SIDEWALK.
- * FOR THICKNESS OF SIDEWALK AT THE BACK OF RAMP, REFER TO STD DWG 2301 SHEET 2 OF 3

CODING NOTES:

(A) SEE SHEETS 2 AND 3 FOR DETECTABLE WARNING DETAILS

PERPENDICULAR CURB RAMP BRICK SIDEWALK

CITY OF COLUMBUS, OHIO
DEPARTMENT OF PUBLIC SERVICE
DIVISION OF DESIGN AND CONSTRUCTION

STD DWG

2319

07/01/2024

SHT 19 OF 23

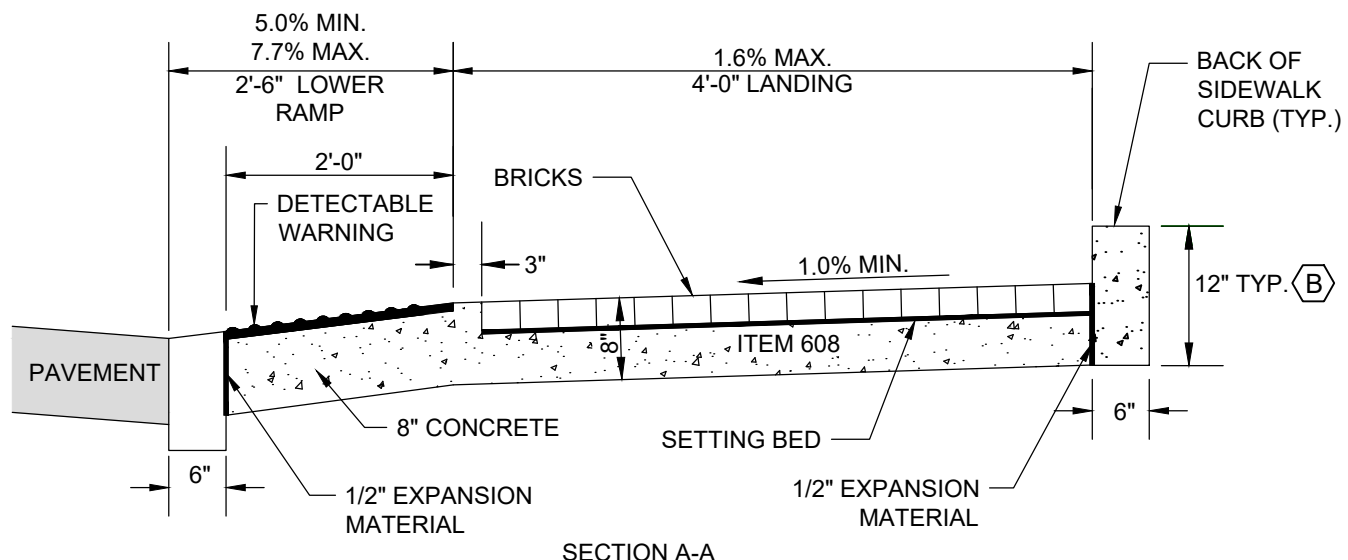
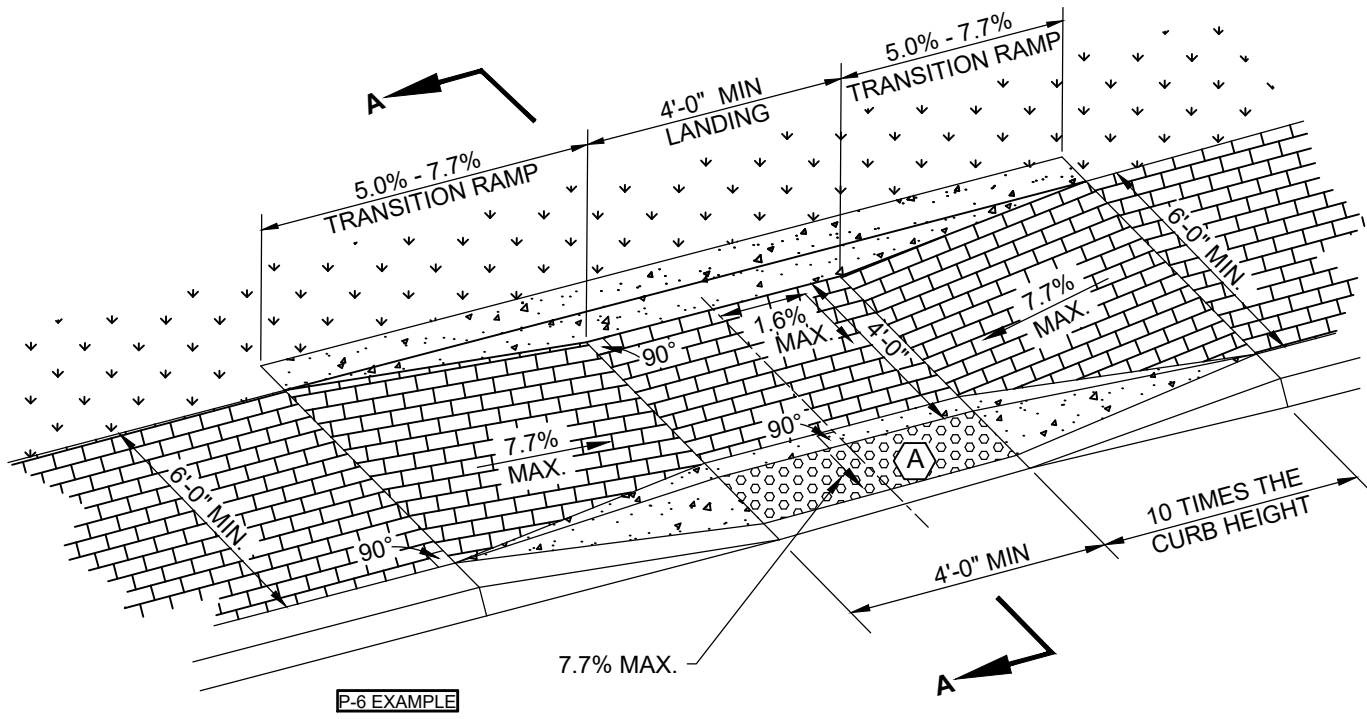

CODING NOTES:

- (A) SEE SHEETS 2 AND 3 FOR DETECTABLE WARNING DETAILS
- (B) EXPOSED REVEAL MUST EQUAL BURIED DEPTH; 12" MAXIMUM REVEAL; FOR ADDITIONAL DETAILS SEE CURB WALL SPECIFICATION

GENERAL NOTES:

SEE SHEETS 2 AND 3 FOR ADDITIONAL DETAILED INFORMATION.

<h1 style="margin: 0;">PARALLEL BRICK RAMP</h1>	
CITY OF COLUMBUS, OHIO DEPARTMENT OF PUBLIC SERVICE DIVISION OF DESIGN AND CONSTRUCTION	STD DWG <h2 style="margin: 0;">2319</h2> 07/01/2024 SHT 20 OF 23

P-4 EXAMPLE

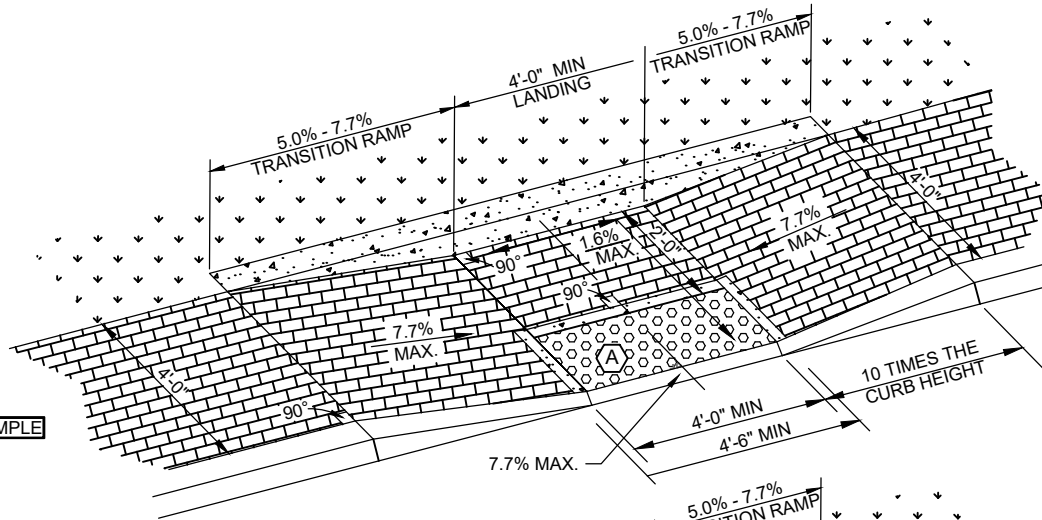

P-5 EXAMPLE

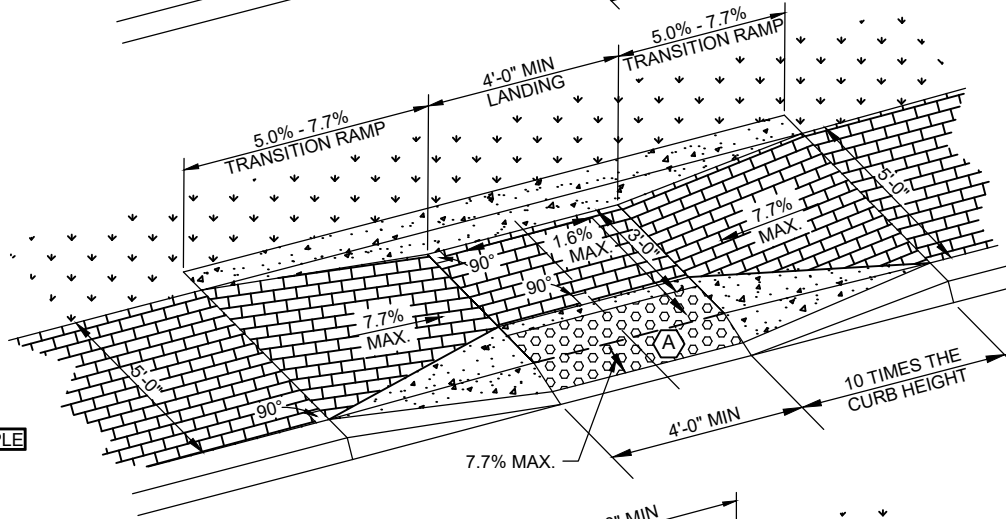

P-7 EXAMPLE

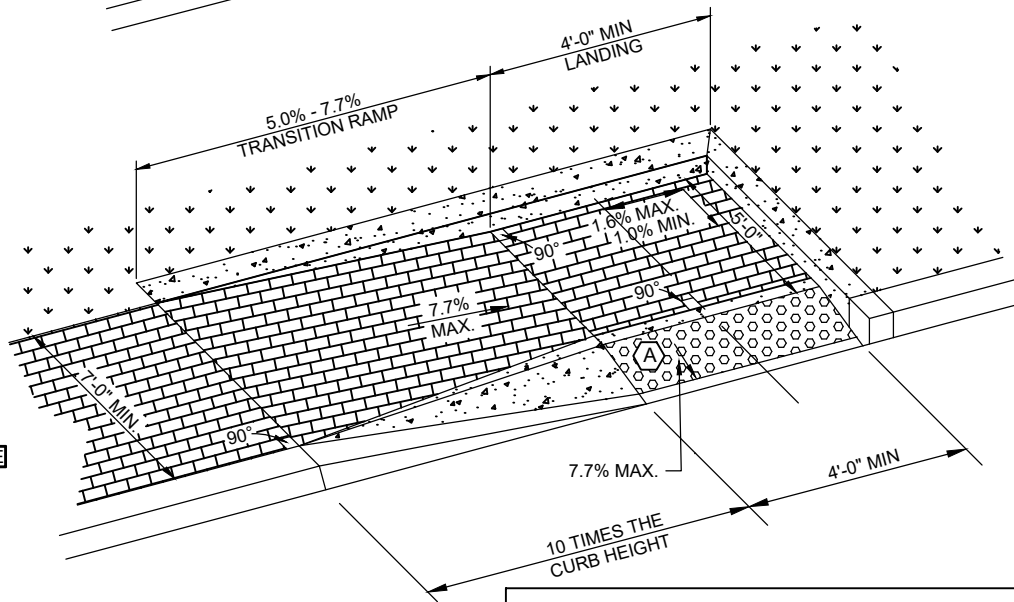

CODED NOTES:

(A) SEE SHEETS 2 AND 3 FOR DETECTABLE WARNING DETAILS

(B) EXPOSED REVEAL MUST EQUAL BURIED DEPTH; 12" MAXIMUM REVEAL; FOR ADDITIONAL DETAILS SEE CURB WALL SPECIFICATION

GENERAL NOTES:

SEE SHEETS 2 AND 3 FOR ADDITIONAL DETAILED INFORMATION.

PARALLEL BRICK RAMPS

CITY OF COLUMBUS, OHIO
DEPARTMENT OF PUBLIC SERVICE
DIVISION OF DESIGN AND CONSTRUCTION

STD DWG

2319

07/01/2024

SHT 21 OF 23

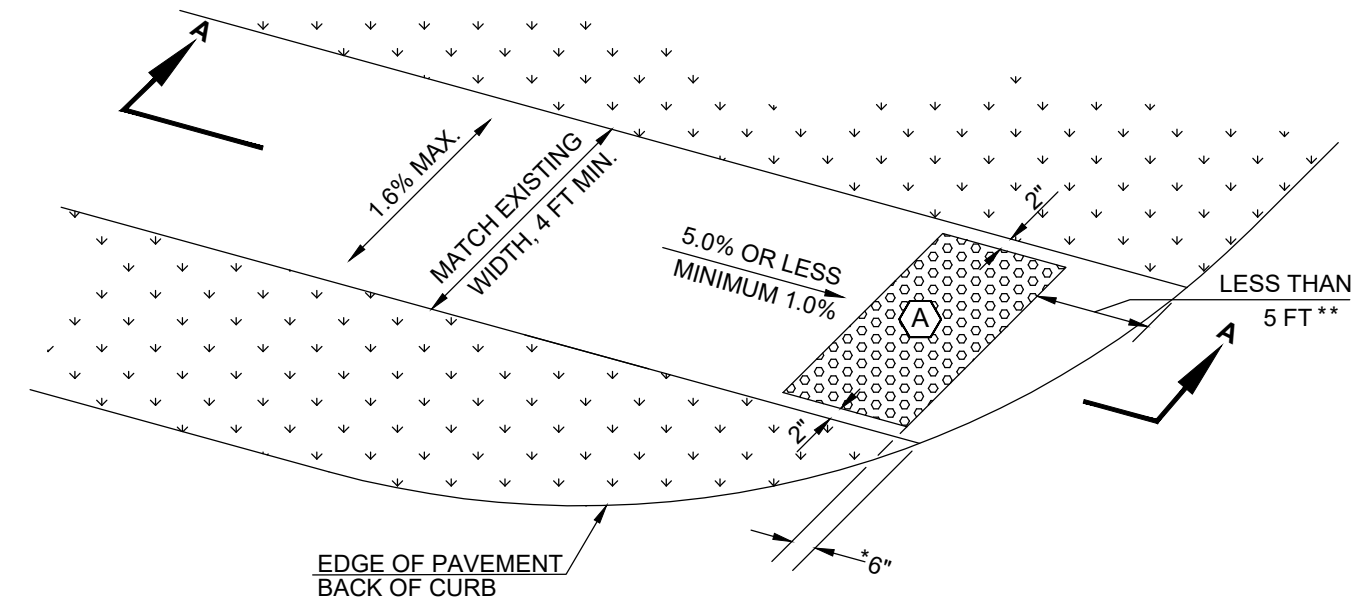

EDGE OF PAVEMENT
BACK OF CURB

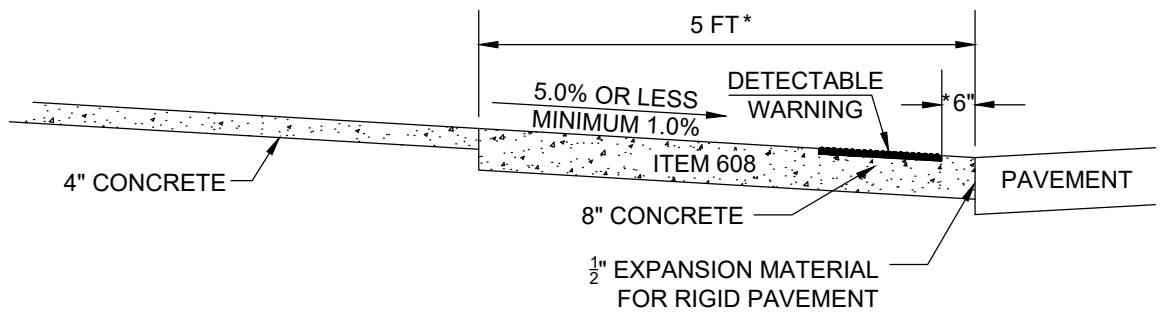

SECTION A-A

A SEE SHEETS 2 AND 3 FOR DETECTABLE WARNING DETAILS

NOTE:

BLENDED TRANSITIONS MAY BE INSTALLED WHERE THE SIDEWALK CAN BE CONNECTED TO THE STREET WITHOUT EXCEEDING A 5.0% RUNNING SLOPE. BLENDED TRANSITIONS DO NOT REQUIRE A TURNING SPACE.

* AS MEASURED FROM EDGE CLOSEST TO PARALLEL ROADWAY

** FOR DIMENSION EQUAL OR GREATER THAN 5 FT, REFER TO SCD 2319 CURB RAMP TYPE G FOR DETECTABLE WARNING ALIGNMENT

<h1>BLENDED TRANSITION</h1>	
CITY OF COLUMBUS, OHIO DEPARTMENT OF PUBLIC SERVICE DIVISION OF DESIGN AND CONSTRUCTION	STD DWG 2319 07/01/2024 SHT 22 OF 23

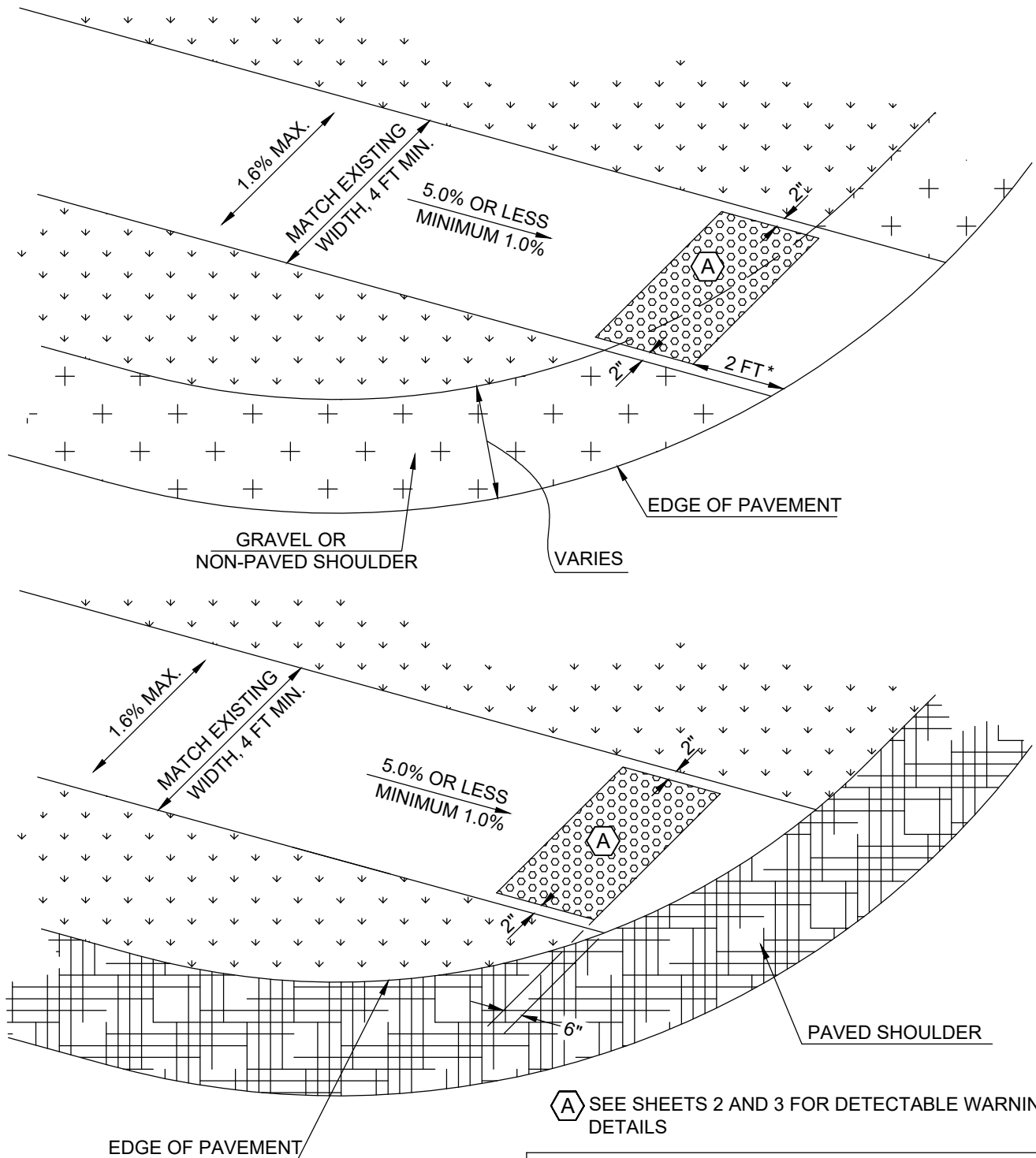

(A) SEE SHEETS 2 AND 3 FOR DETECTABLE WARNING DETAILS

NOTE:

* DETECTABLE WARNING SHALL BE PLACED 2 FT BEHIND THE EDGE OF PAVEMENT WHEN GRAVEL SHOULDER IS PRESENT. DETECTABLE WARNING MAY BE ADJUSTED UP TO 4 FT MAXIMUM BEHIND THE EDGE OF PAVEMENT IF THERE IS EVIDENCE OF OVERTRACKING OF RADIUS.

BLENDING TRANSITION AT ROADWAY WITH SHOULDER

CITY OF COLUMBUS, OHIO
 DEPARTMENT OF PUBLIC SERVICE
 DIVISION OF DESIGN AND CONSTRUCTION

STD DWG
2319
 07/01/2024
 SHT 23 OF 23